



SMEAD INVESTOR OASIS // SMEAD CAPITAL MANAGEMENT

Manias in American CapEx Cycles

Presented by:
Cole Smead, CFA
CEO & Portfolio Manager

Opinions expressed are those of Smead Capital Management, are subject to change, are not guaranteed, and should not be considered recommendations to buy or sell any security.



Agenda

- **Railway Mania of the 1880s**
- **The Telecom Bubble**
- **Drill Baby Drill of the 2010s**
- **Today's AI Hyper-Scaling Mania**
- **Investment Excitement Ratio**
- **The Returns that Follow**



Railway Mania of the 1880s

EMERGING TECHNOLOGY

- Steel rails (more durable)
- Janney-style automatic coupler (easier connection)
- Westinghouse air brake
- Signal systems via telegraph

20
26

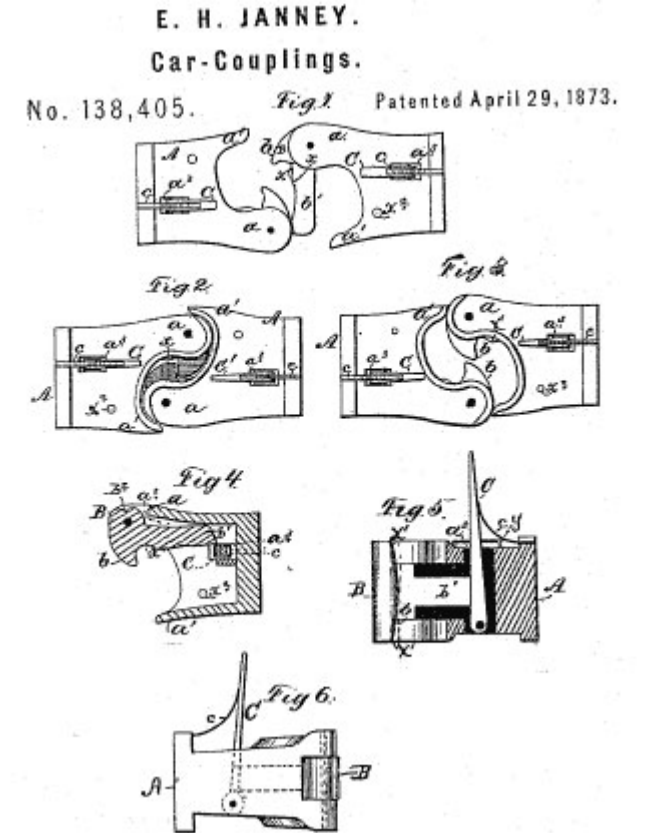
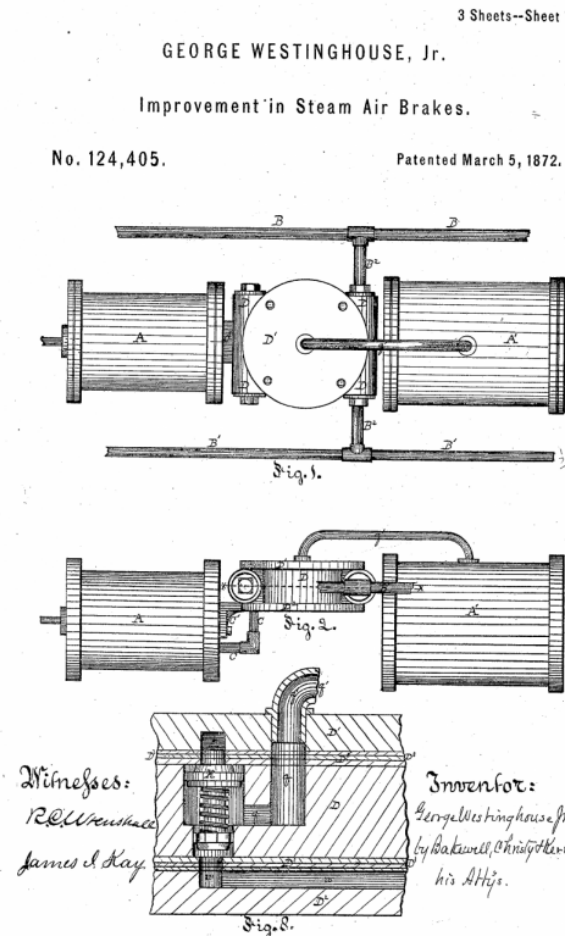



Railway Mania of the 1880s

REAL ECONOMIC APPLICATIONS

- Time travel from east to west took six months or more
 - 12-14 miles per day on the Oregon Trail
 - Six months or more via South America
 - Six months or more via the Panama Isthmus
- When the Transcontinental Railroad opened in 1869, the trip from New York to Sacramento went down to seven days

20
26



Railway Mania of the 1880s

MARKET CONCENTRATION IN RAILROADS

Year	Approximate Railroad Share of US Market Cap (%)
1850	85
1860	80
1870	70
1880	65
1890	55
1900	45
1910	35
1920	25
1930	20
1940	15
1950	10
1960	5
1970	4
1980	3
1990	2
2000	2
2010	2
2020	1
2025	0.6

Past performance is no guarantee of future results. Source: Global Financial Data.

20
26



Railway Mania of the 1880s

RAMP OF FUNDRAISING

- III. Why Did Railroads Rely So Heavily on Debt Finance? Theoretical Considerations

Why did creditors agree to lend so much money to railroads? Weren't creditors aware that railroads were risky? Actually, railroads were seen, ex ante, as a low-risk sector, which would be ideal for conservative investors. During the 19th Century, railroad firms (along with utilities) had access to national markets for long-term debt, while industrial firms did not.

- “Once debt contracts are entered into, managers with an equity interest in the firm may have an incentive to take on greater risk, because they are only concerned with expanding the upper tail of the asset returns distribution” (Calomiris 1995, paraphrasing Jensen and Meckling 1976).



Railway Mania of the 1880s

THINGS TO WATCH FOR IN THE ECONOMY

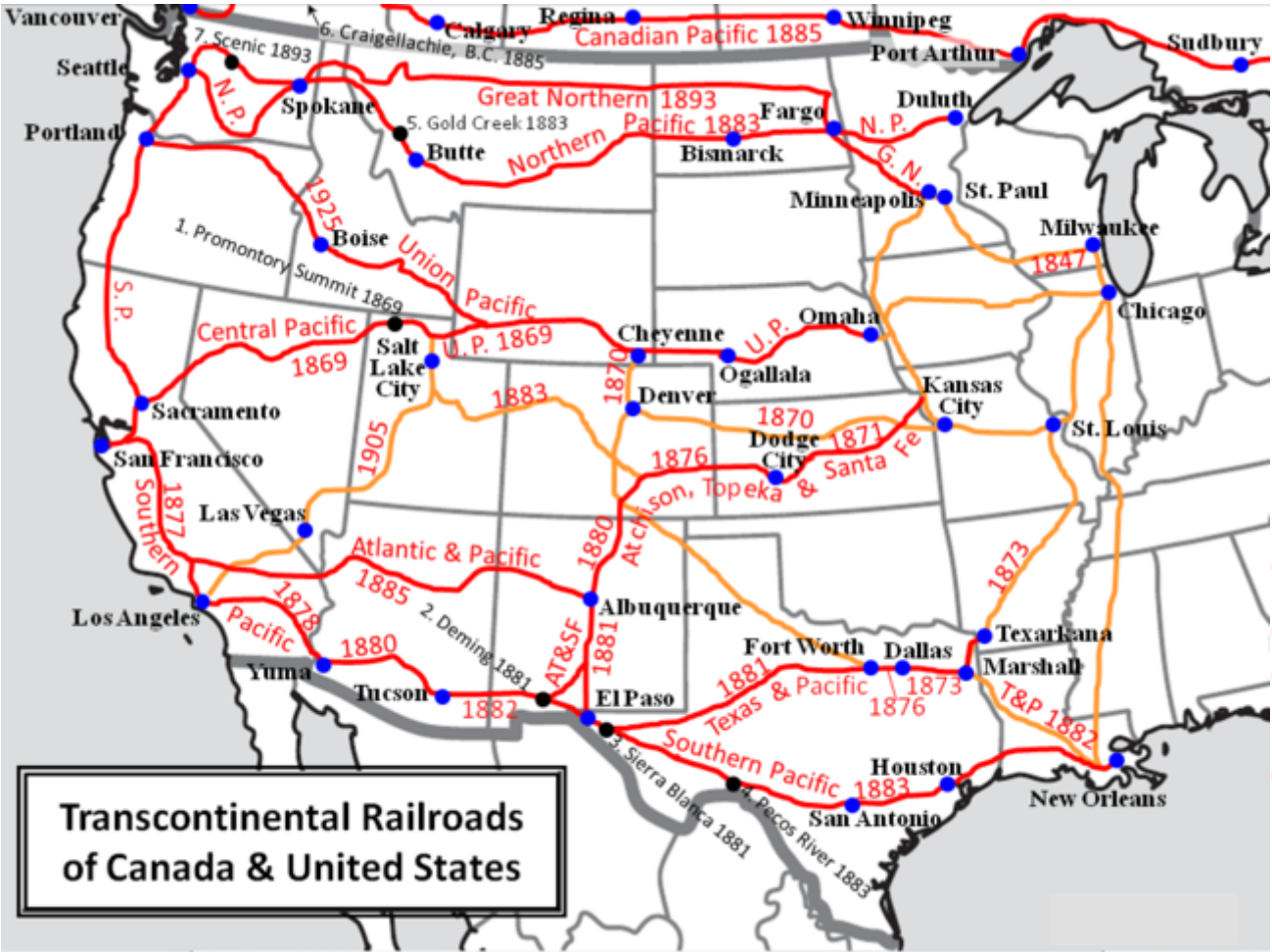

Transcontinental Railroads of Canada & United States

20
26

Past performance is no guarantee of future results. Source: Museum of the American Railroad.



Railway Mania of the 1880s

COMPETITION

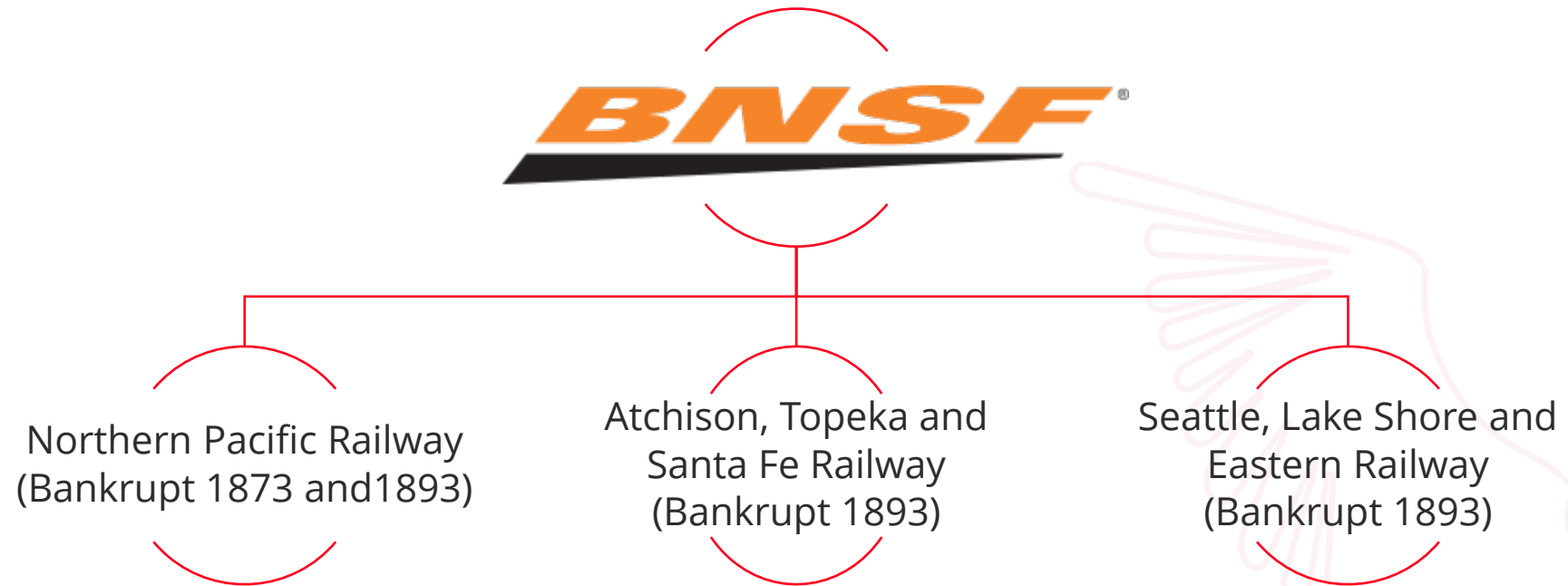

20
26



Railway Mania of the 1880s

COMPETITION

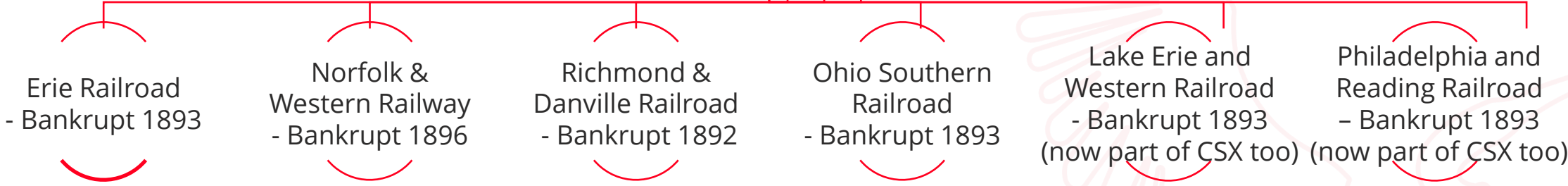

20
26

Past performance is no guarantee of future results. Source: BNSF.com.



Railway Mania of the 1880s

COMPETITION

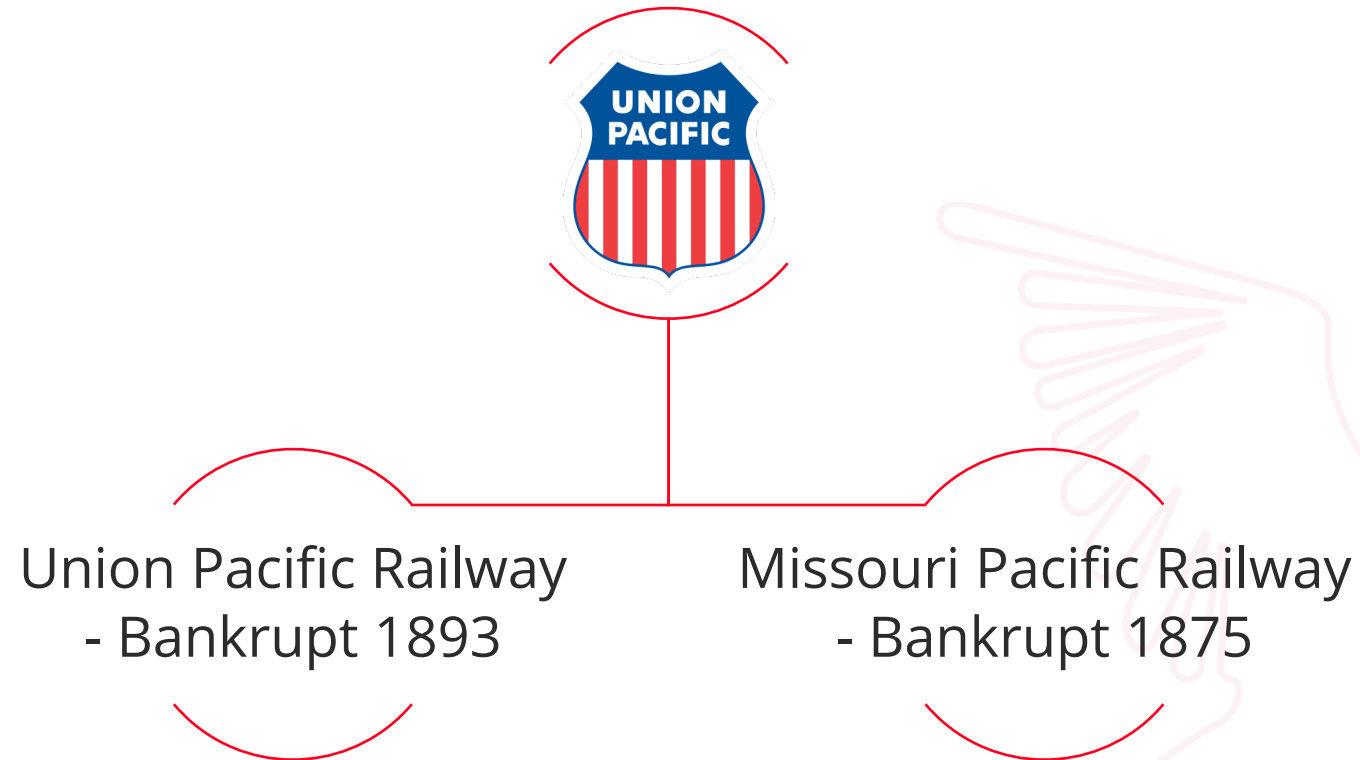

20
26



Railway Mania of the 1880s

COMPETITION

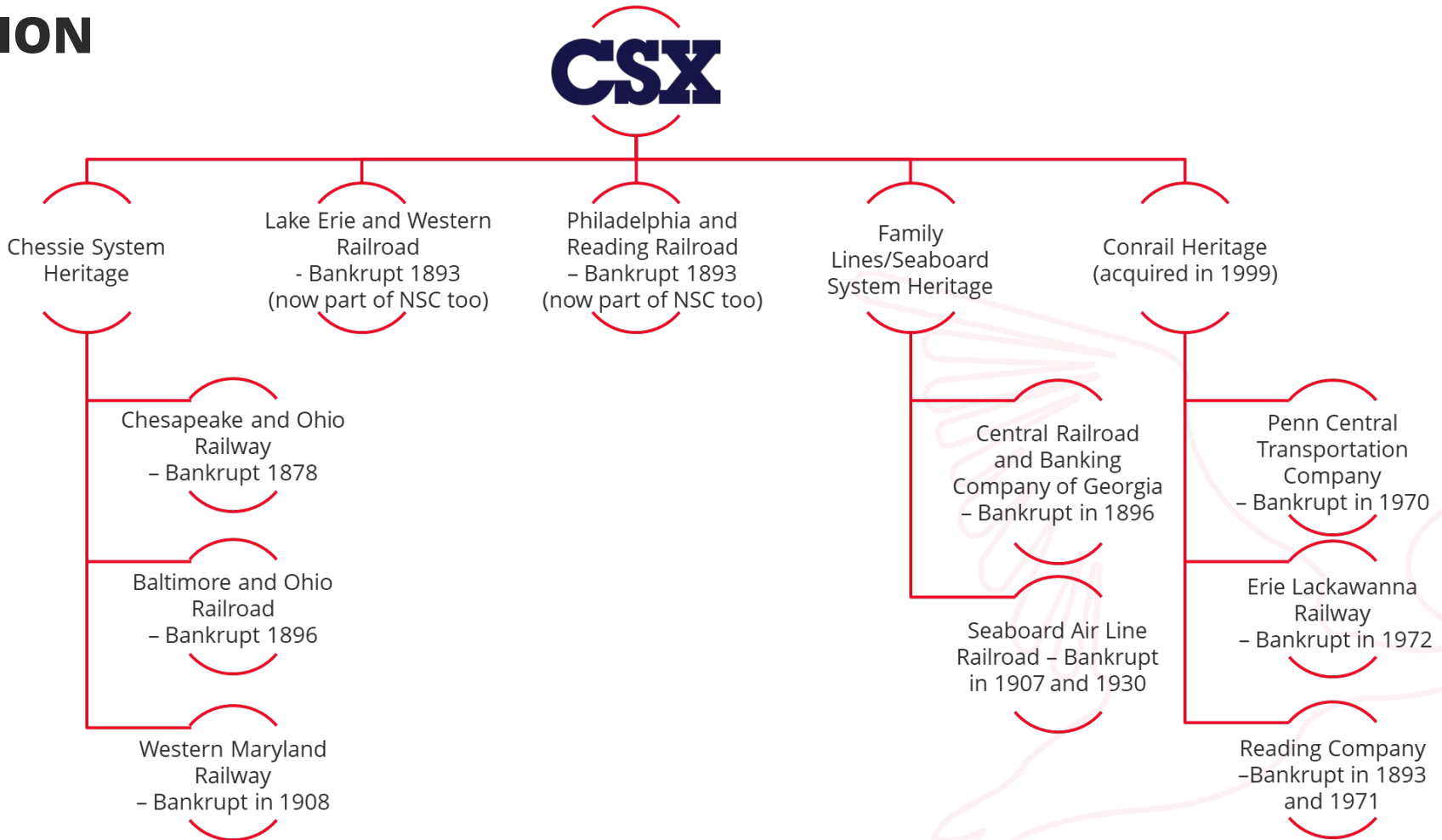

20
26

Past performance is no guarantee of future results. Source: <https://case.edu/ech/articles/c/csx-corp>.



Railway Mania of the 1880s

COMPETITION

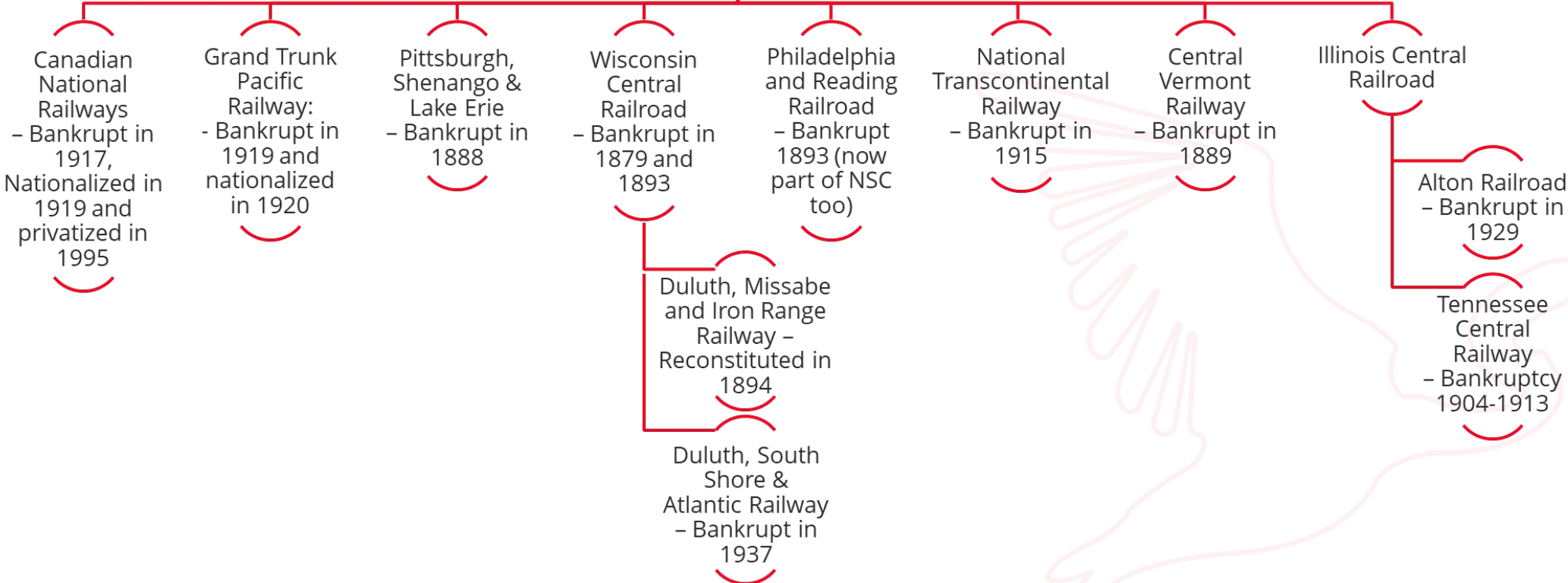

20
26

Past performance is no guarantee of future results. Source: <https://www.cn.ca/en/about-cn/history/>.



Railway Mania of the 1880s

COMPETITION

CPKC

Kansas City, Pittsburg and Gulf Railroad - Bankrupt in 1900

Gulf & Mississippi Railroad - Bankrupt in 1988

Chicago, Milwaukee, St. Paul and Pacific Railroad - Bankrupt in 1925

Duluth, South Shore and Atlantic Railway - Bankrupt in 1937

Delaware and Hudson Railway - Bankrupt in 1988

Montreal, Maine and Atlantic Railway - Bankrupt in 2013

Canadian American Railroad - Bankrupt in 2002

20
26

Past performance is no guarantee of future results. Source: <https://www.trains.com/trn/railroads/history/canadian-pacific-merger-family-tree/>.



Railway Mania of the 1880s

SIZE OF CAPITAL EXPENDITURES

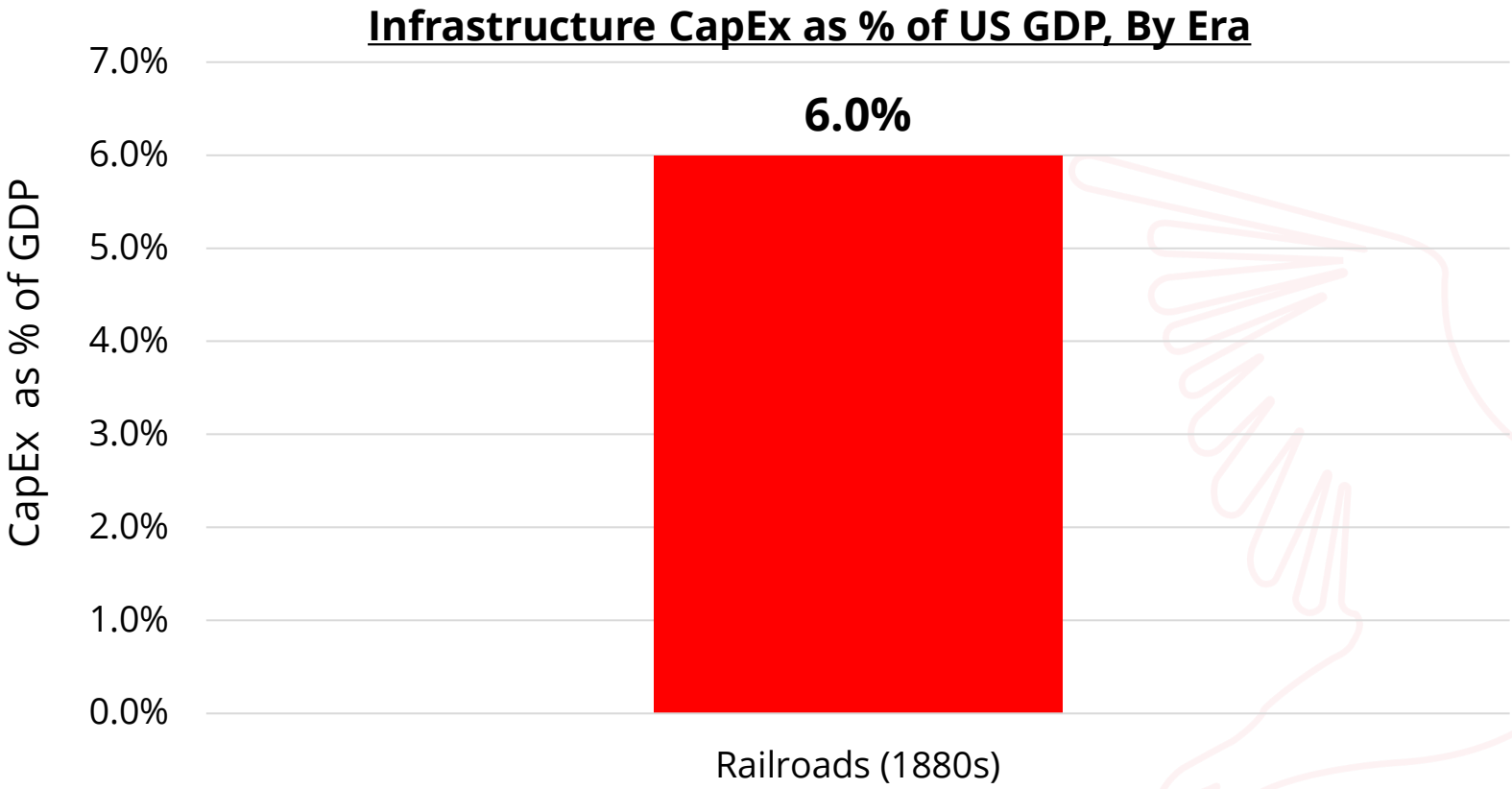

Past performance is no guarantee of future results. Source: paulkedrosky.com, Jens Nordvig.

Agenda

- ✓ **Railway Mania of the 1880s**
- **The Telecom Bubble**
- **Drill Baby Drill of the 2010s**
- **Today's AI Hyper-Scaling Mania**
- **Investment Excitement Ratio**
- **The Returns that Follow**



The Telecom Bubble

Connecting To America Online...



Cancel



EMERGING TECHNOLOGY

Past performance is no guarantee of future results.





The Telecom Bubble

REAL ECONOMIC APPLICATION

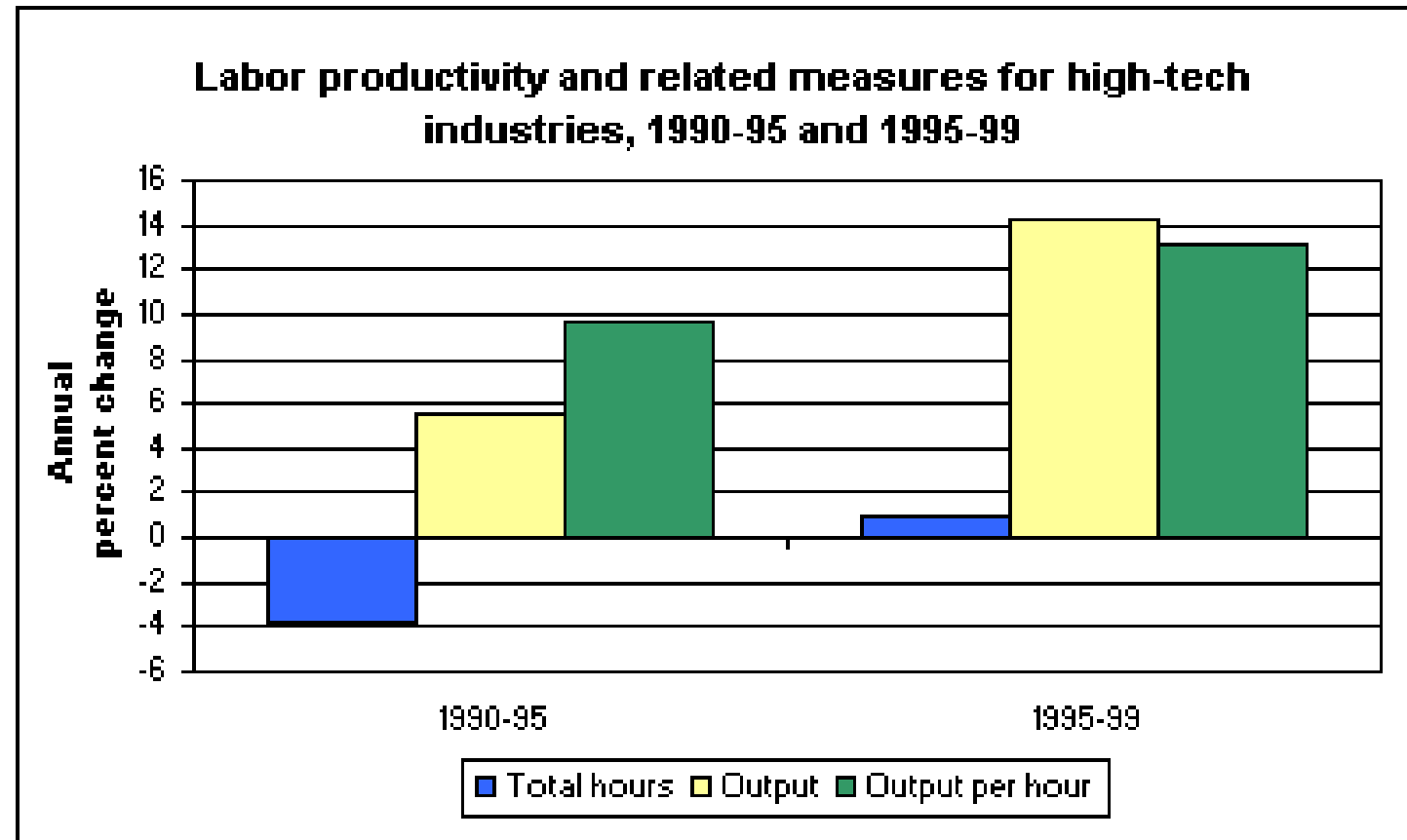

Past performance is no guarantee of future results. Source: United States Bureau of Labor Statistics.



The Telecom Bubble

INVESTOR EXCITEMENT

Figure 1: Global cellular subscriptions per hundred and the US/European Telco sector price performance.

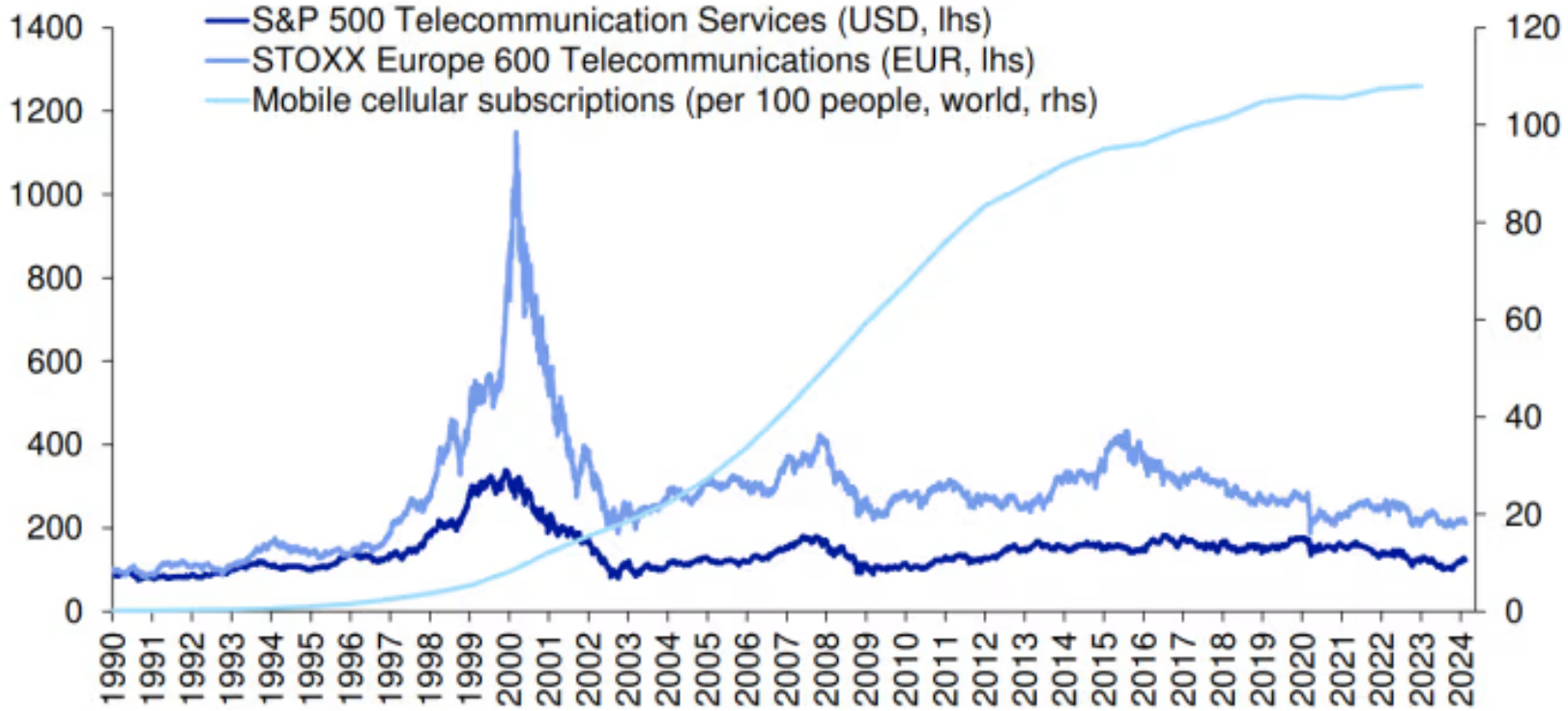

Source : Bloomberg Finance LP, World Bank, Deutsche Bank

Past performance is no guarantee of future results. Source: Bloomberg, World Bank, Deutsche Bank.

20
26



The Telecom Bubble

RAMP OF FUNDRAISING (EQUITY/DEBT)

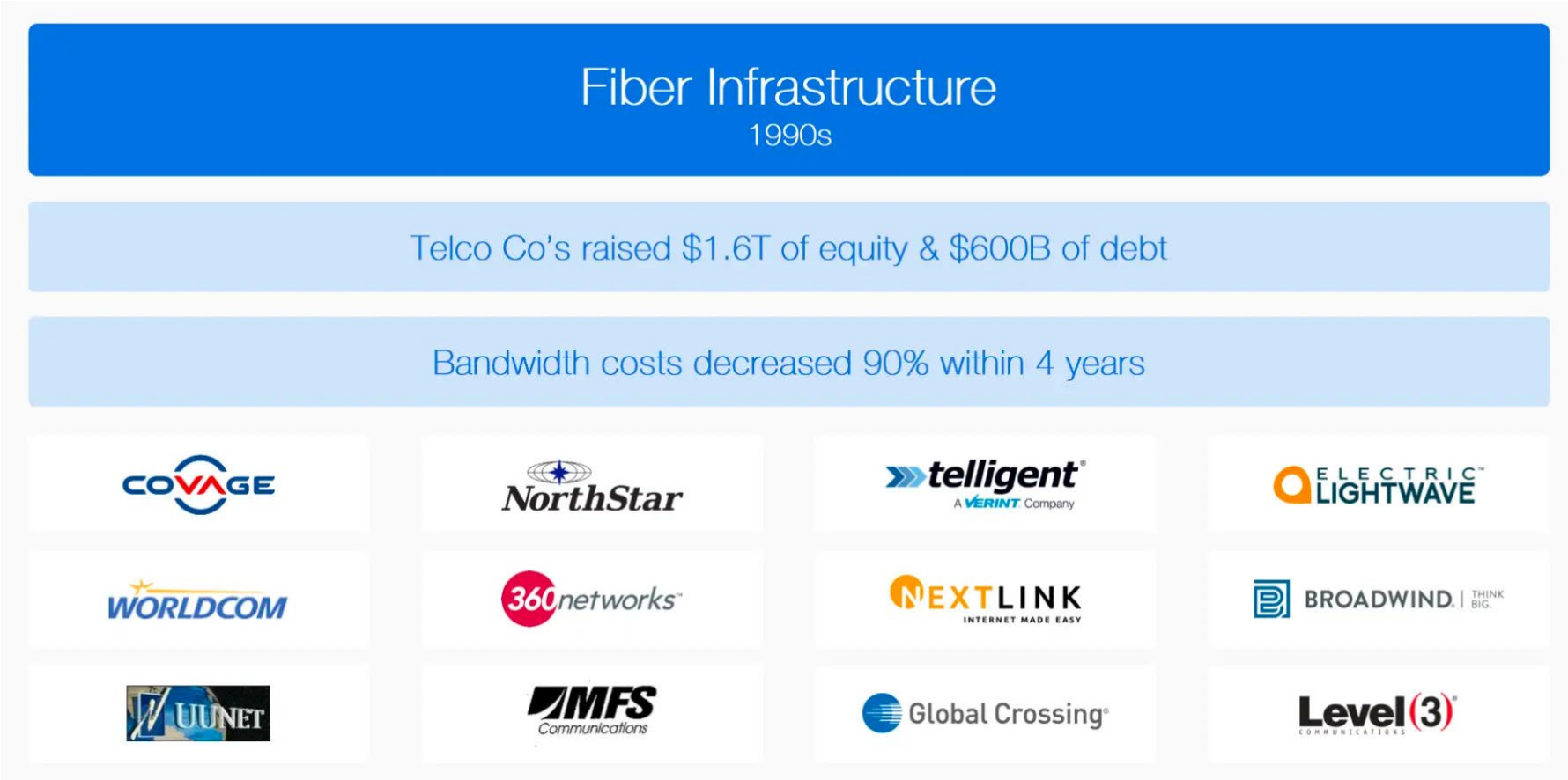

20
26

Past performance is no guarantee of future results. Source: <https://blog.boxcars.ai/p/making-it-up-in-volume-how-the-a>.



The Telecom Bubble

COMPETITION

TABLE 5. SUMMARY OF TELECOMMUNICATIONS M&A ACTIVITY, 1993-2000.

Year	No. of Mergers	Total Value ¹ (\$ billions)	Average Value ¹ (\$ billions)
1993	1	12.6	12.6
1994	0	0	0
1995	2	12.9	6.4
1996	3	56.3	18.8
1997	7	2.2	.5
1998	23	62.9	3.9
1999	30	808.3	26.9
2000	27	507.0	18.8

¹ Disclosed activity only

Source: Calculated by author from various sources.



The Telecom Bubble

LEVERAGE

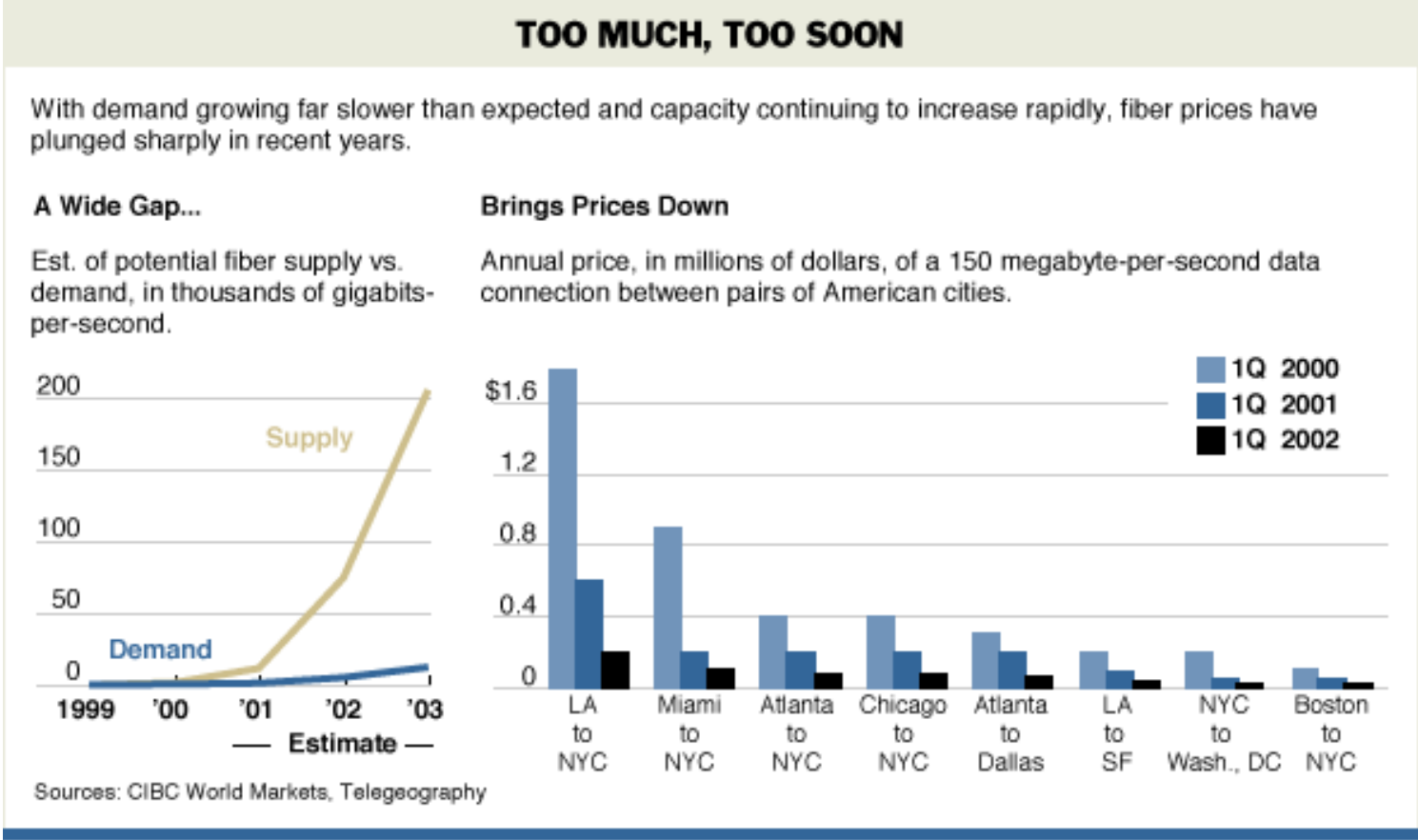

20
26

Past performance is no guarantee of future results. Source: CIBC World Markets, Telegeography, Wall Street Journal.



The Telecom Bubble

SIZE OF CAPITAL EXPENDITURES

US GDP was \$10.25 trillion in 2000.

Telecom spending as a percentage of GDP was **1.18%**

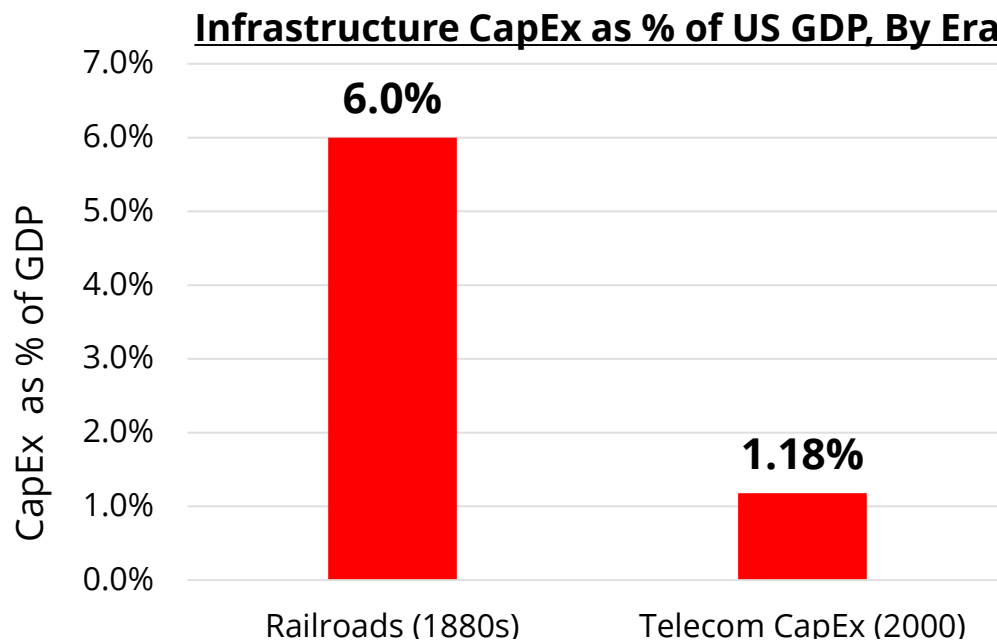
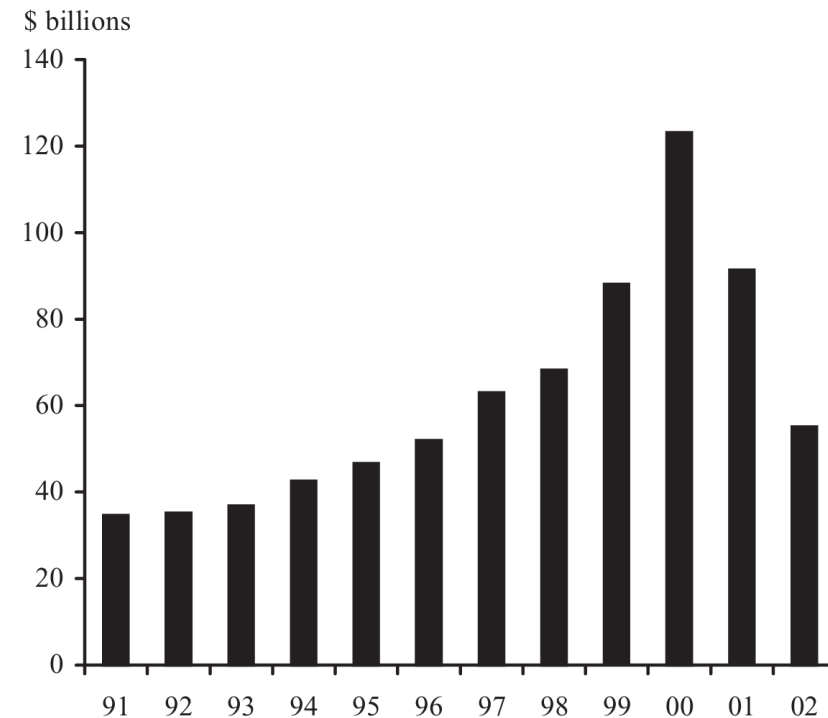

FIGURE 4
CAPITAL SPENDING BY PUBLICLY TRADED
TELECOMMUNICATIONS SERVICE PROVIDERS



Source: Compustat and author's calculations.

Agenda

- ✓ **Railway Mania of the 1880s**
- ✓ **The Telecom Bubble**
- **Drill Baby Drill of the 2010s**
- **Today's AI Hyper-Scaling Mania**
- **Investment Excitement Ratio**
- **The Returns that Follow**





Drill Baby Drill of the 2010s

EMERGING TECHNOLOGY

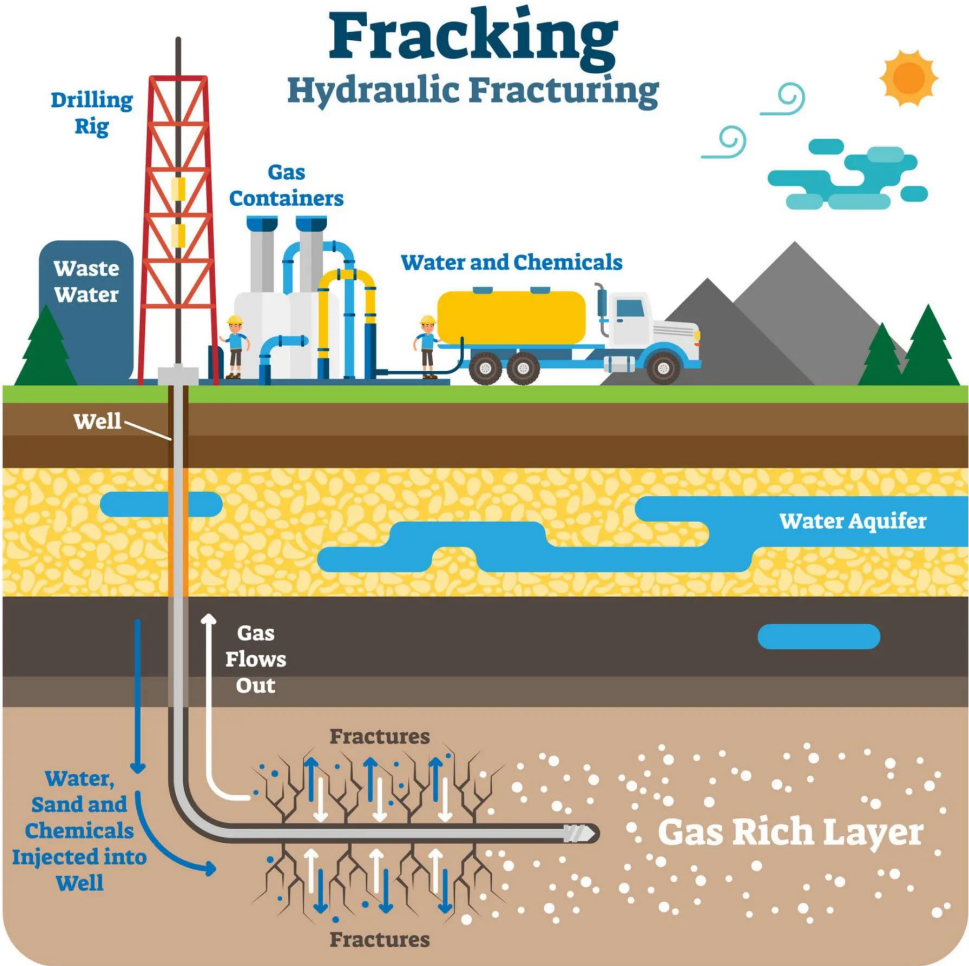

20
26

Past performance is no guarantee of future results. Source: Energies Media.



Drill Baby Drill of the 2010s

REAL ECONOMIC APPLICATION

U.S. natural gas imports and exports, 1950-2022

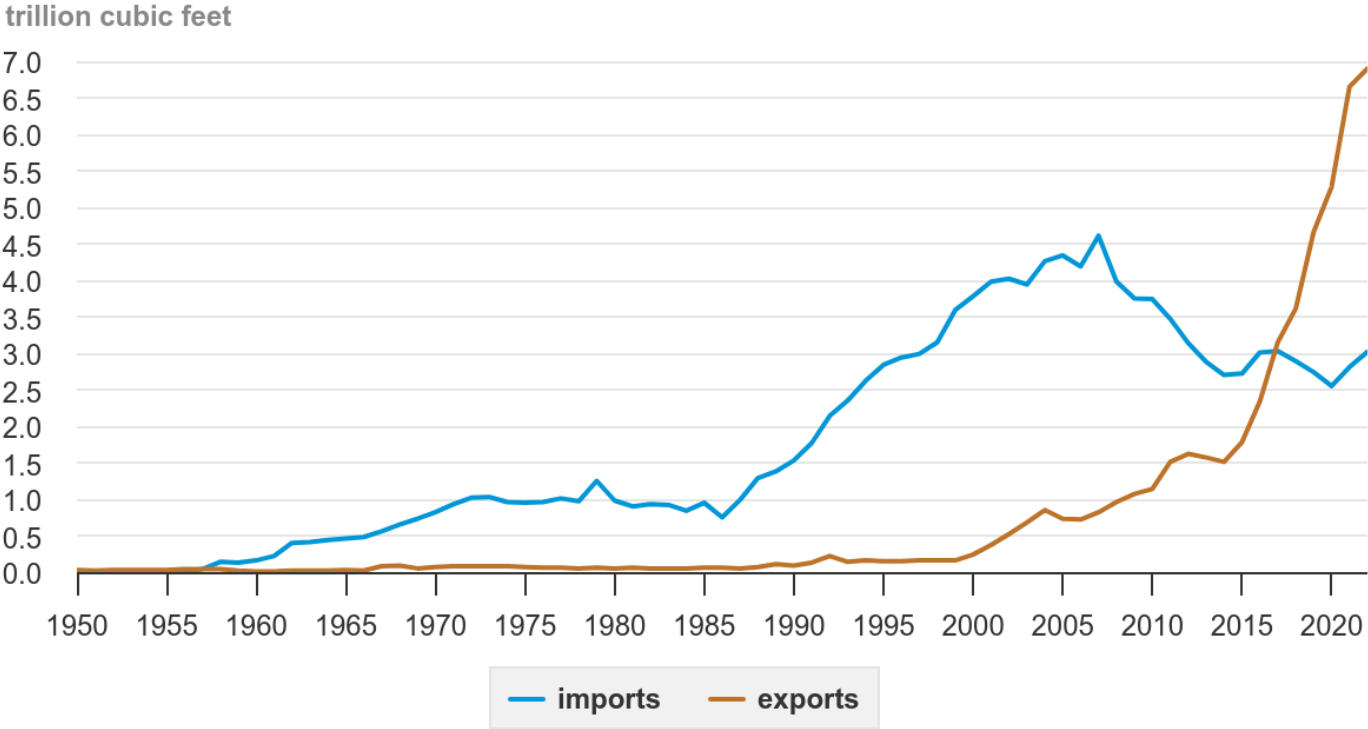

eia Data source: U.S. Energy Information Administration, *Natural Gas Monthly*, April 2023; data for 2022 are preliminary

Past performance is no guarantee of future results. Source: EIA.

Drill Baby Drill of the 2010s



INVESTOR EXCITEMENT

Past performance is no guarantee of future results. Source: Gregory Zuckerman, The Economist.





Drill Baby Drill of the 2010s

RAMP OF FUNDRAISING (EQUITY/DEBT)

U.S. oil-and-gas producers debt and equity issuance

■ Debt ■ Equity

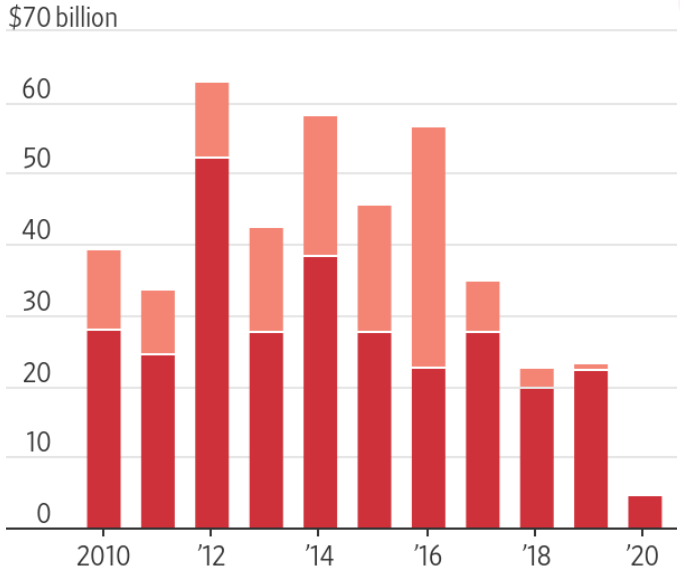

Note: 2020 data are year-to-date
Source: Dealogic

Past performance is no guarantee of future results. Source: Dealogic, Wall Street Journal.

20
26



Drill Baby Drill of the 2010s

COMPETITION



20
26

Past performance is no guarantee of future results. Source: Bloomberg.



Drill Baby Drill of the 2010s

LEVERAGE

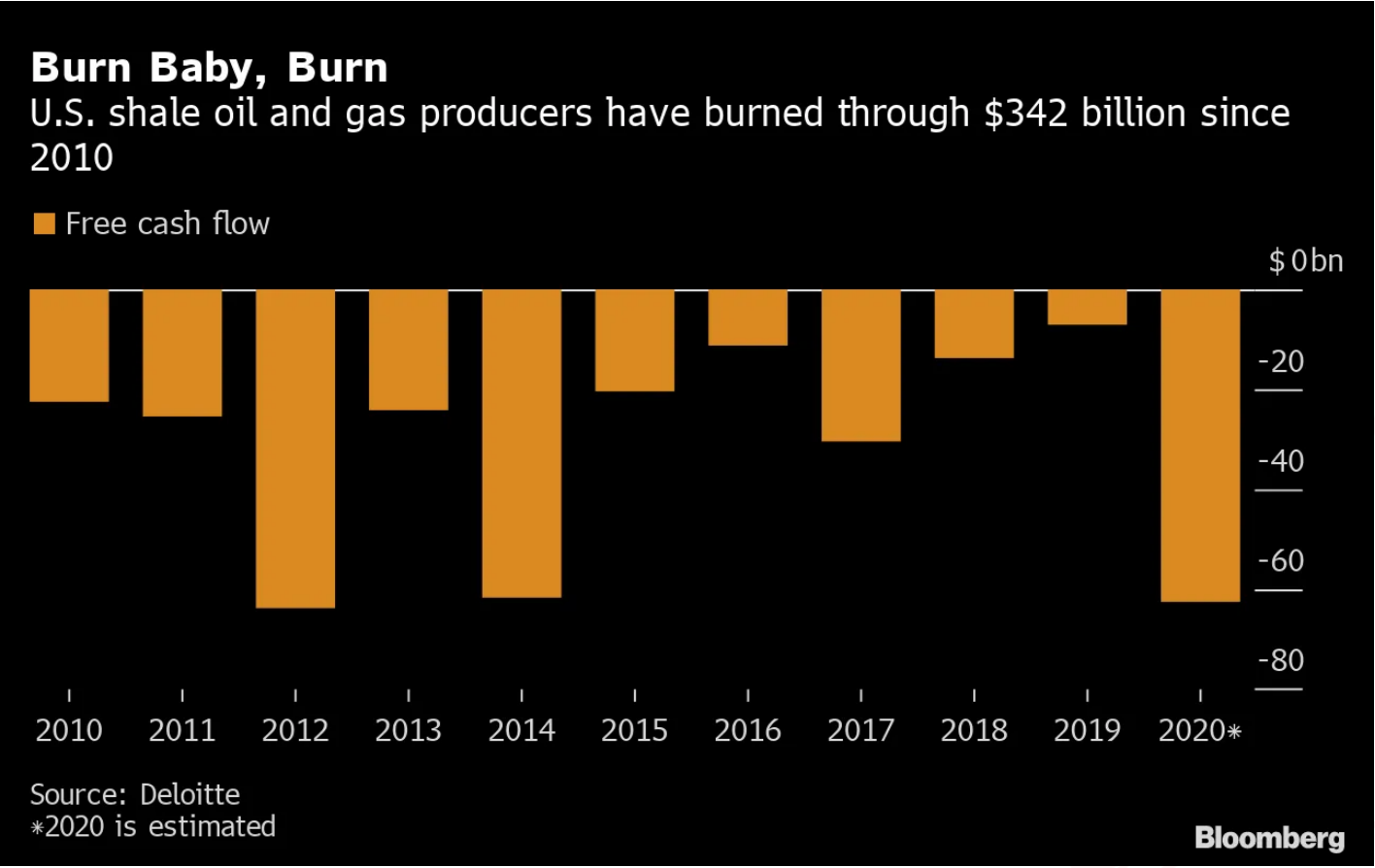

20
26

Past performance is no guarantee of future results. Source: Bloomberg.



Drill Baby Drill of the 2010s

LEVERAGE

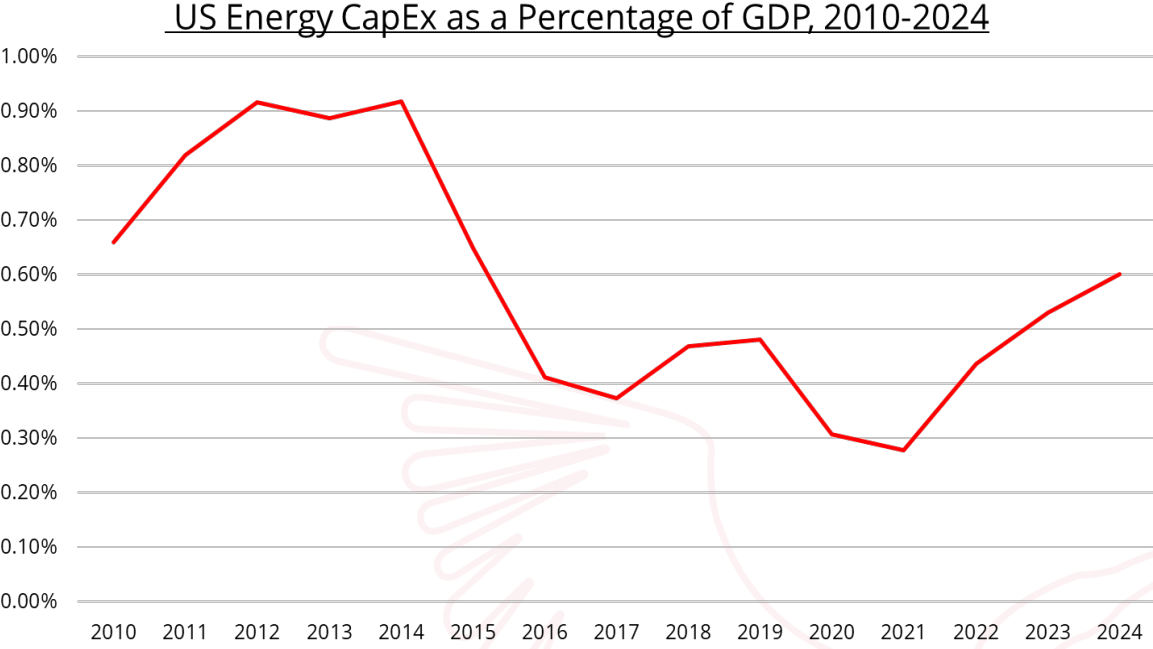
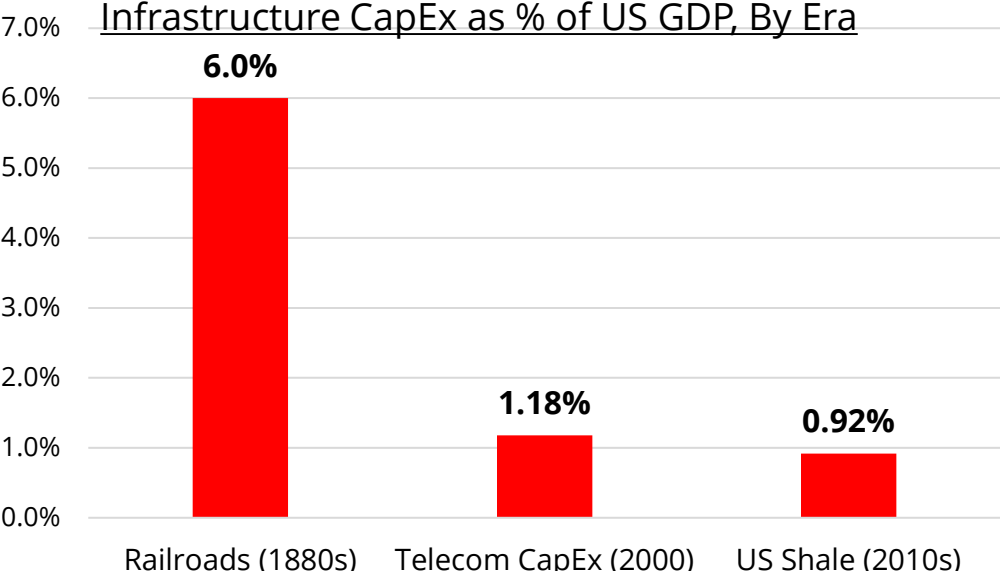

20
26

Past performance is no guarantee of future results. Source: Bloomberg.

Agenda

- ✓ **Railway Mania of the 1880s**
- ✓ **The Telecom Bubble**
- ✓ **Drill Baby Drill of the 2010s**
- **Today's AI Hyper-Scaling Mania**
- **Investment Excitement Ratio**
- **The Returns that Follow**





Today's AI Hyper-Scaling Mania

EMERGING TECHNOLOGY

Explainer: ChatGPT - what is OpenAI's chatbot and what is it used for?

By Siddharth K

December 5, 2022 1:54 PM MST · Updated December 6, 2022

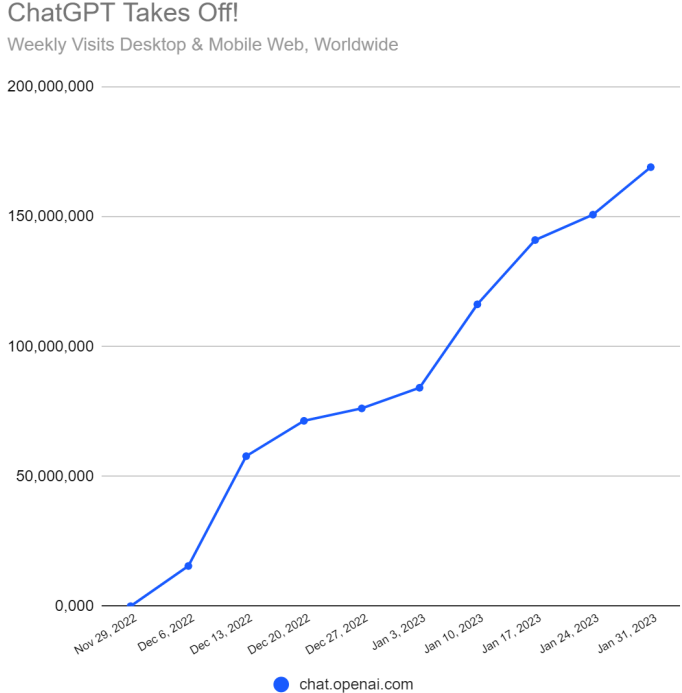
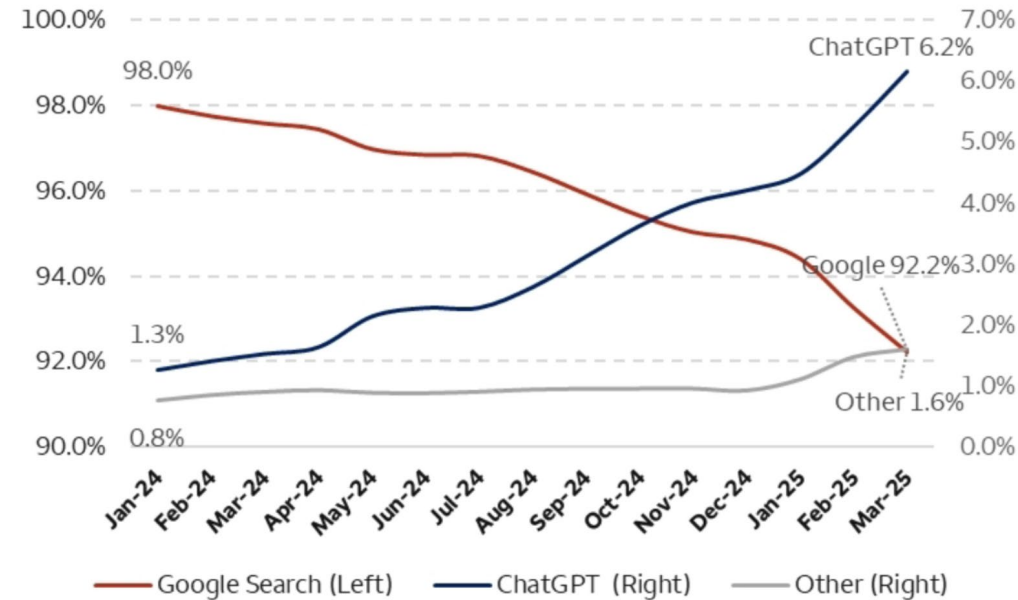

Exhibit 2 - Share Mix - Search and AI Agent Global Usage Instance



Source: Wells Fargo Securities, LLC Estimates, SimilarWeb, SensorTower
Usage instance is defined as the sum of total web visit and app sessions. Other includes DeepSeek, Bing, Grok, Claude, and Perplexity.

Past performance is no guarantee of future results. Source: Reuters, SimilarWeb, SensorTower, Wells Fargo Securities



Today's AI Hyper-Scaling Mania

REAL ECONOMIC APPLICATION

AI's impact on labor productivity depends on its capability and adoption timeline

Effect of AI adoption on annual labor productivity growth, 10-year adoption period

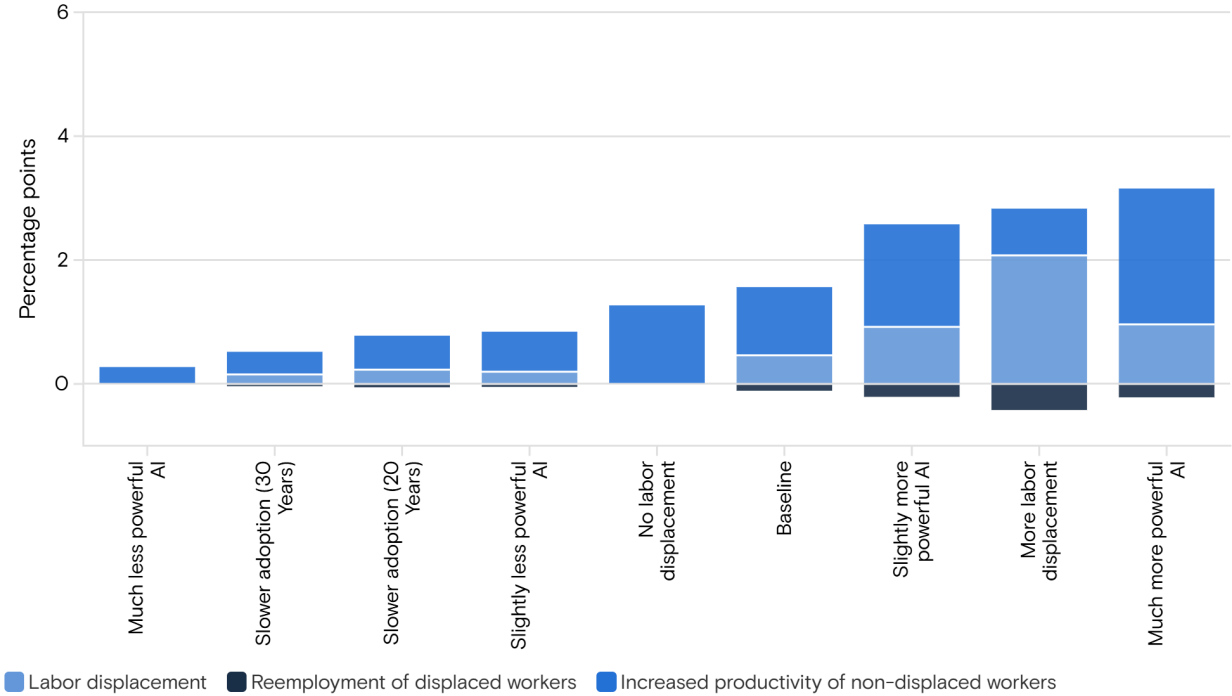

Source: Goldman Sachs Research



20
26

Past performance is no guarantee of future results.



Today's AI Hyper-Scaling Mania

PRODUCTIVITY GAINS

APOLLO

How has your firm's use of AI affected your firm?

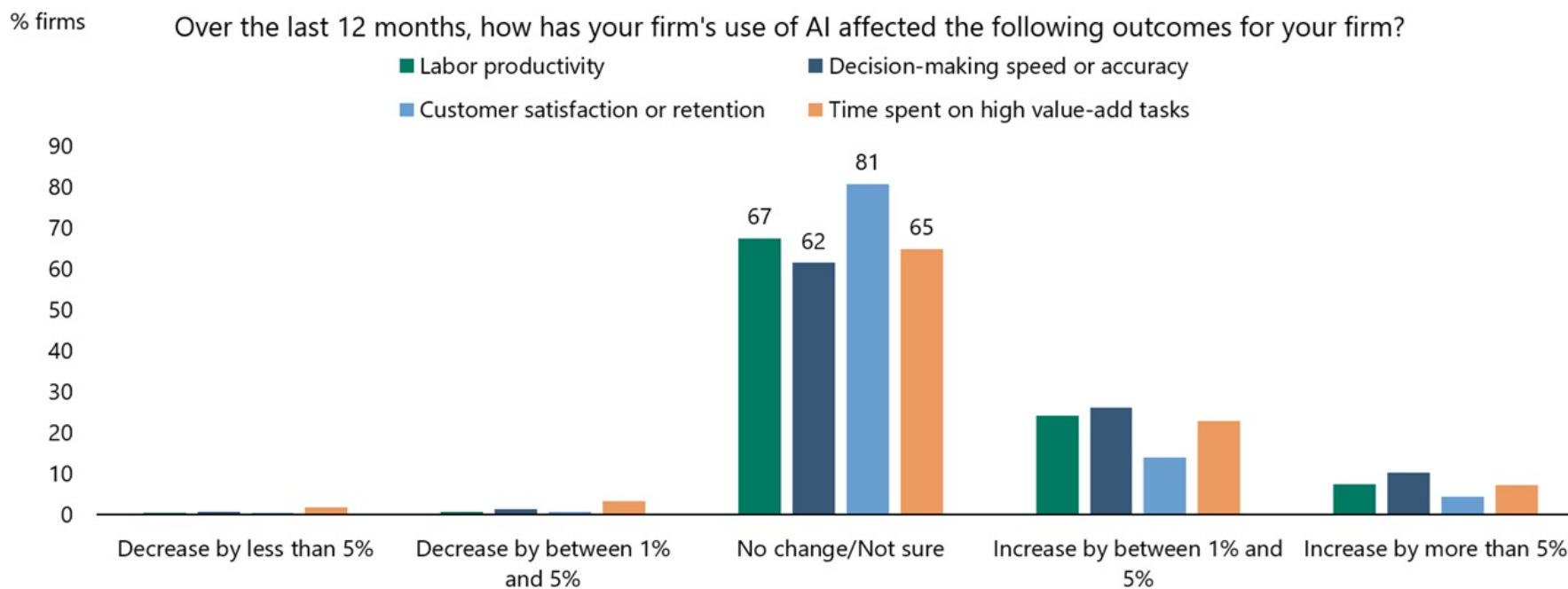

20
26

Past performance is no guarantee of future results. Source: Apollo Global Management.



Today's AI Hyper-Scaling Mania

INVESTOR EXCITEMENT

AI investment a major factor across all venture stages

Total cash raised by US startups on Carta in 2024 | AI Companies | Other

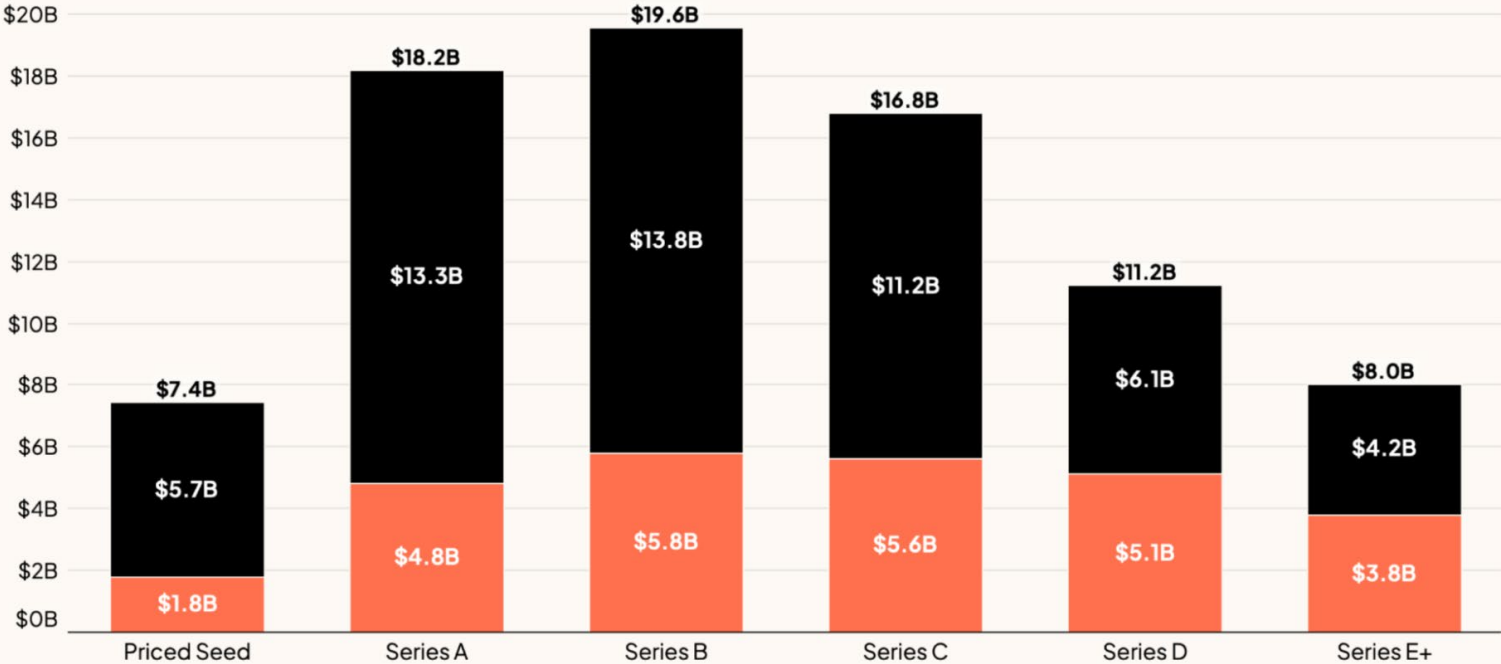

©2025 eShares Inc., d/b/a Carta Inc. ("Carta"). All rights reserved



20
26

Past performance is no guarantee of future results. Source: Carta.



Today's AI Hyper-Scaling Mania

RAMP OF FUNDRAISING

Global AI VC investment

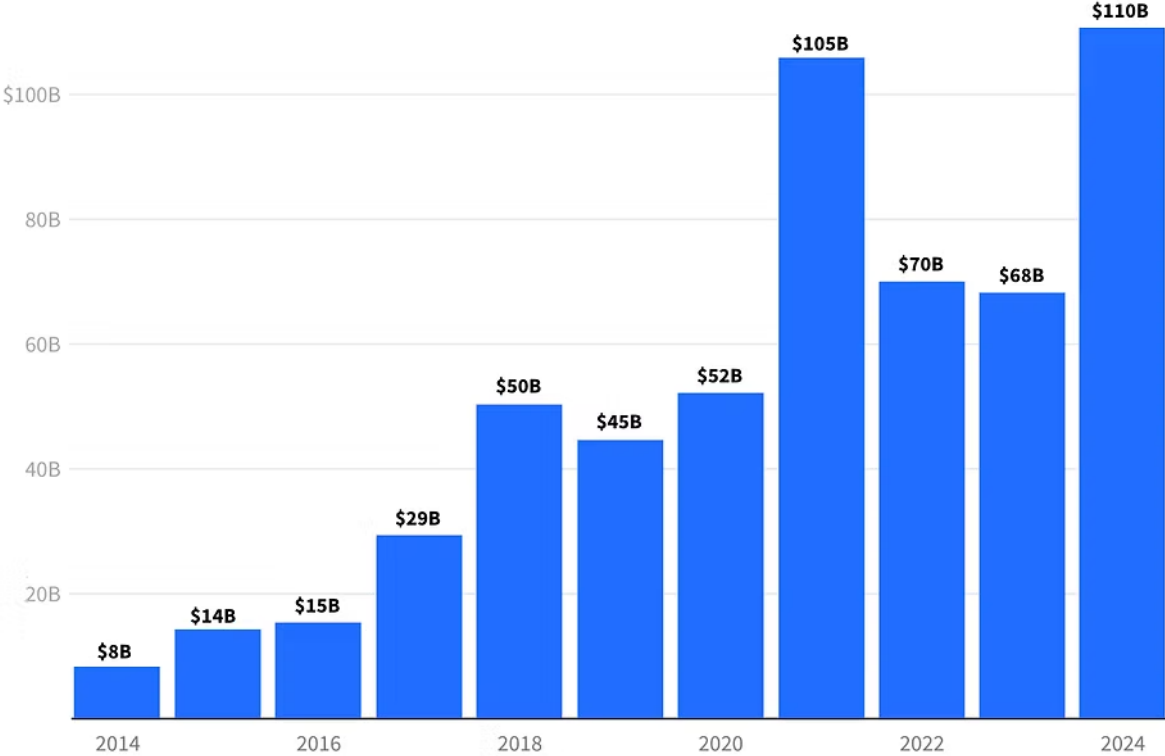

Source: Dealroom.co

dealroom.co

Past performance is no guarantee of future results. Source: dealroom.co.

20
26



Today's AI Hyper-Scaling Mania

RAMP OF FUNDRAISING (EQUITY/DEBT)

AI S&P 500 Market Concentration

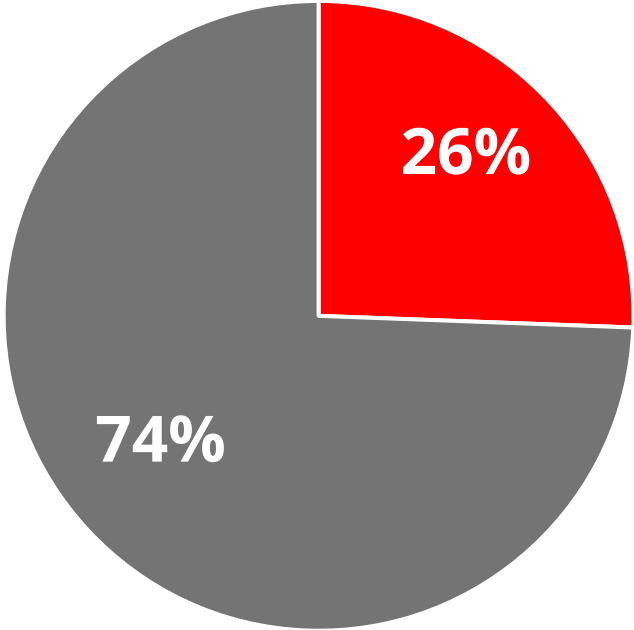

■ AI Market Weight ■ Remaining Stock Market

20
26

Past performance is no guarantee of future results. Source: Bloomberg. "AI Market Weight" defined as S&P 500 index weights of NVDA, MSFT, GOOGL, AMZN, META as of 8/21/2025.



Today's AI Hyper-Scaling Mania

COMPETITION



Gemini



OpenAI



Meta



Grok



Perplexity



Apple Intelligence



DeepSeek



Midjourney



Claude



20
26

Past performance is no guarantee of future results. Source: Bloomberg.



Today's AI Hyper-Scaling Mania

COMPETITION



Office Software



Social Media



Ecommerce



Search and Streaming

20
26



Today's AI Hyper-Scaling Mania

COMPETITION

META Net Cash, 2023-Present

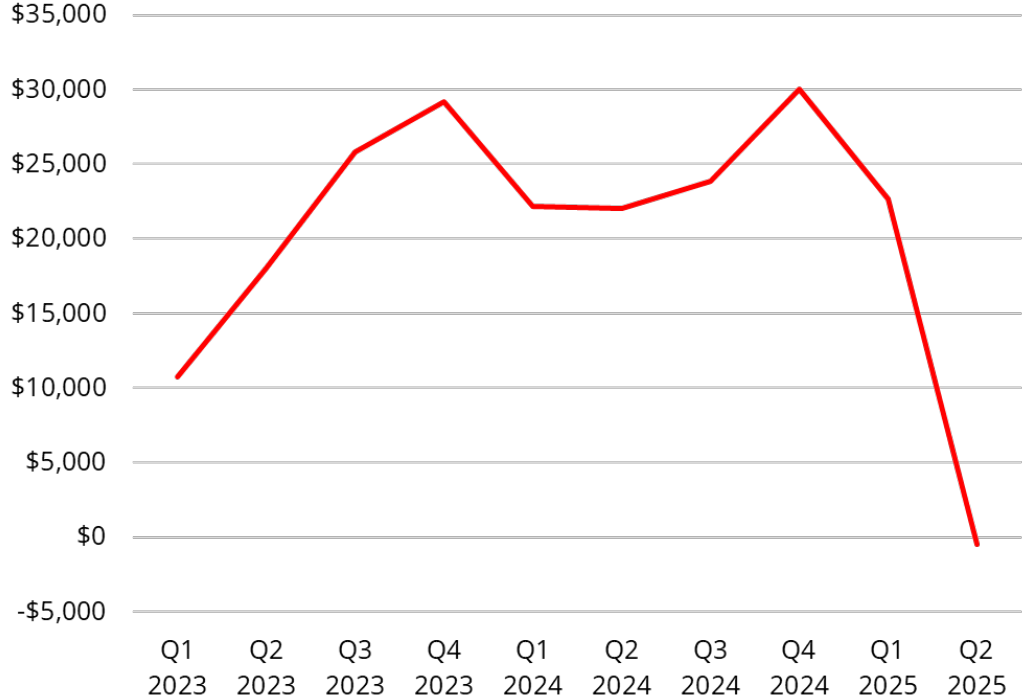

Meta's \$29 Billion Deal Marks Key Moment for Private Credit



A Meta store in Burlingame, California, US. *Photographer: David Paul Morris/Bloomberg*

By [Carmen Arroyo](#) and [Olivia Fishlow](#)

August 8, 2025 at 12:18 PM MST

20
26

Past performance is no guarantee of future results. Source: Bloomberg.



Today's AI Hyper-Scaling Mania

SIZE OF CAPITAL EXPENDITURES

Capital expenditures, quarterly

\$100 billion

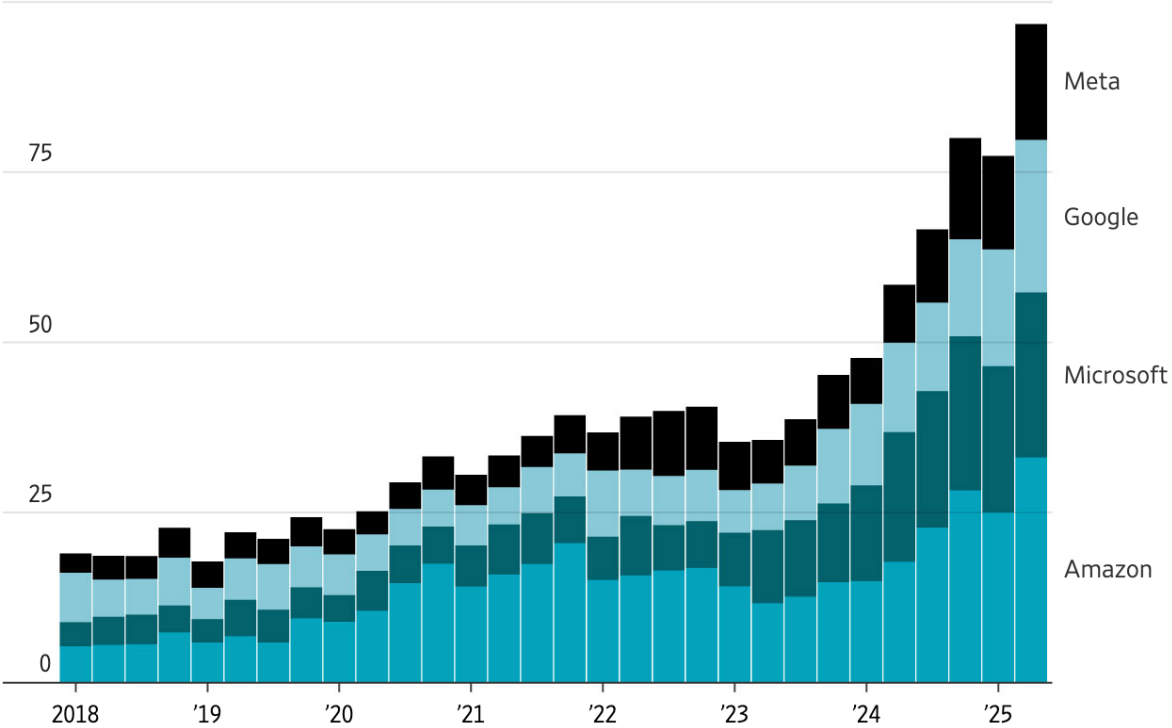

Note: Data are for calendar quarters and include finance leases.

20
26

Past performance is no guarantee of future results. Source: Wall Street Journal.



Today's AI Hyper-Scaling Mania

SIZE OF CAPITAL EXPENDITURES

Infrastructure CapEx as % of US GDP, By Era

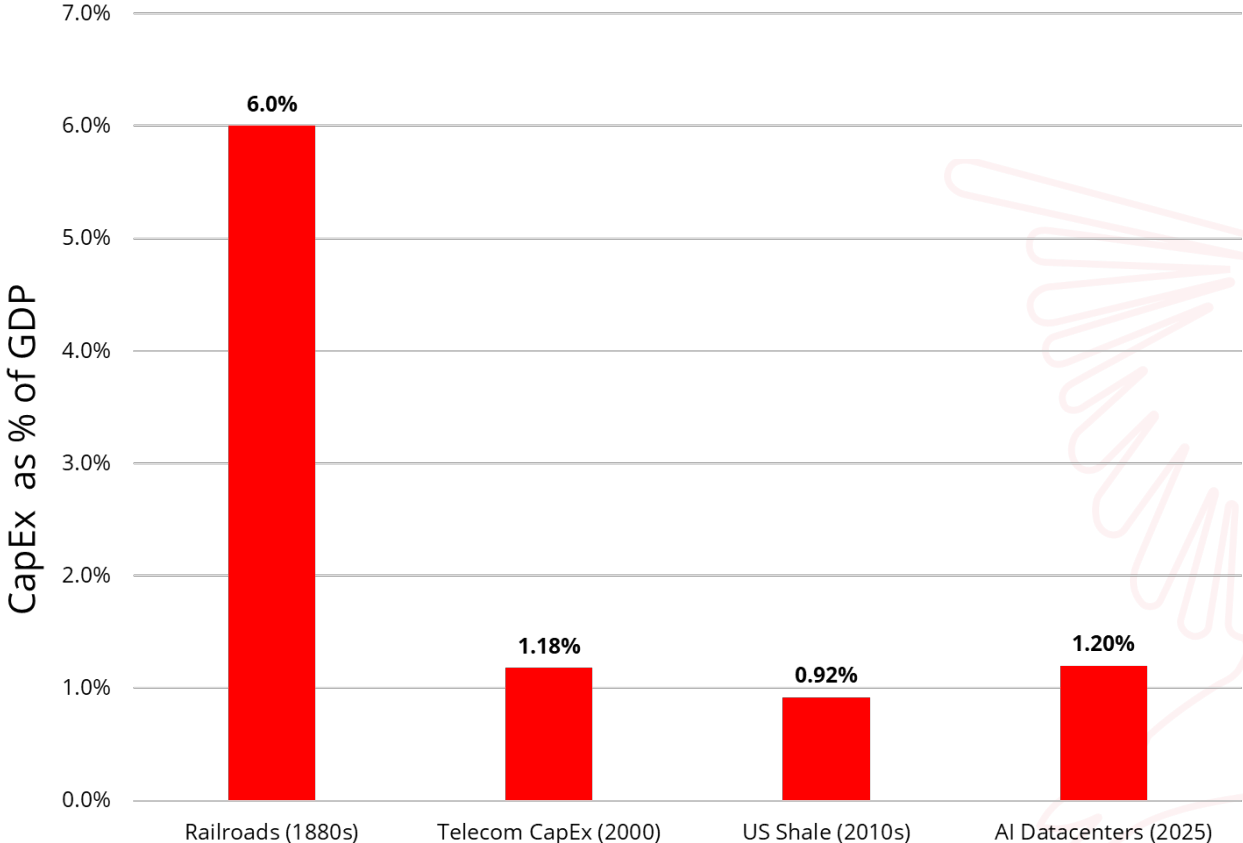

20
26

Past performance is no guarantee of future results. Source: paulkedrosky.com, Jens Nordvig. Federal Reserve Bank of San Francisco



Today's AI Hyper-Scaling Mania

SIZE OF CAPITAL EXPENDITURES

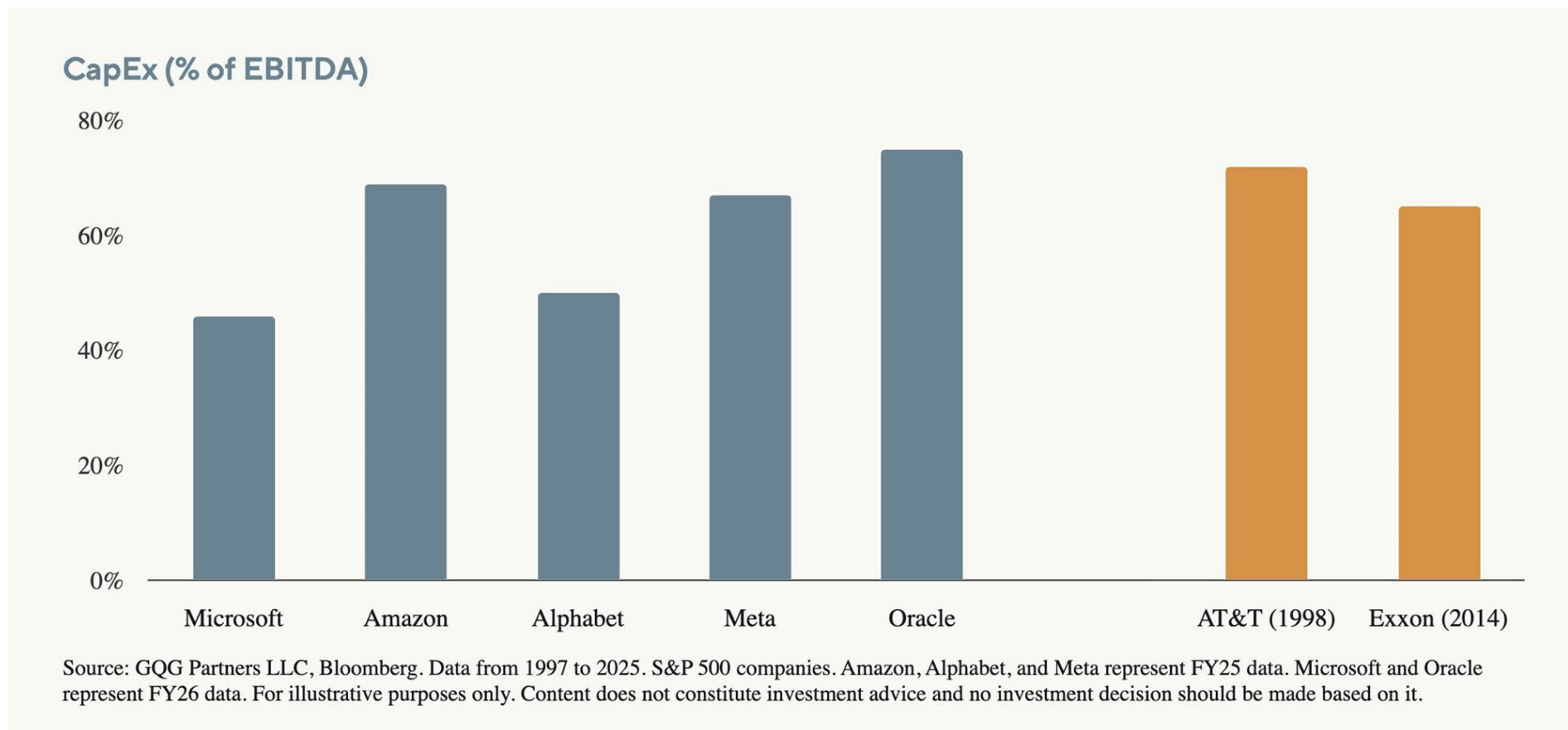

20
26

Agenda

- ✓ **Railway Mania of the 1880s**
- ✓ **The Telecom Bubble**
- ✓ **Drill Baby Drill of the 2010s**
- ✓ **Today's AI Hyper-Scaling Mania**
- **Investment Excitement Ratio**
- **The Returns that Follow**



Today's AI Hyper-Scaling Mania

$$\text{Buffett Indicator} = \frac{\text{Wilshire 5000 Total Market Capitalization}}{\text{United States Gross Domestic Product}}$$

BUFFETT INDICATOR





Today's AI Hyper-Scaling Mania

RAMP OF FUNDRAISING (EQUITY/DEBT)

AI S&P 500 Market Concentration

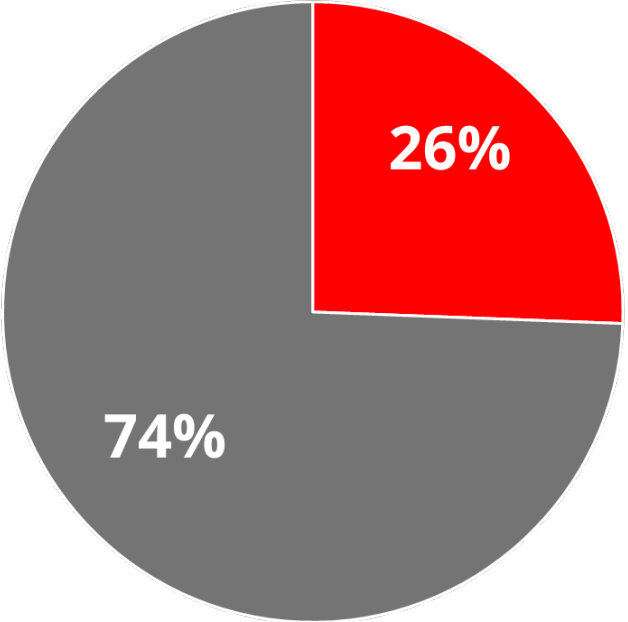

■ AI Market Weight ■ Remaining Stock Market



20
26

Past performance is no guarantee of future results. Source: Bloomberg. "AI Market Weight" defined as S&P 500 index weights of NVDA, MSFT, GOOGL, AMZN, META as of 8/21/2025.



Today's AI Hyper-Scaling Mania

SIZE OF CAPITAL EXPENDITURES

Infrastructure CapEx as % of US GDP, By Era

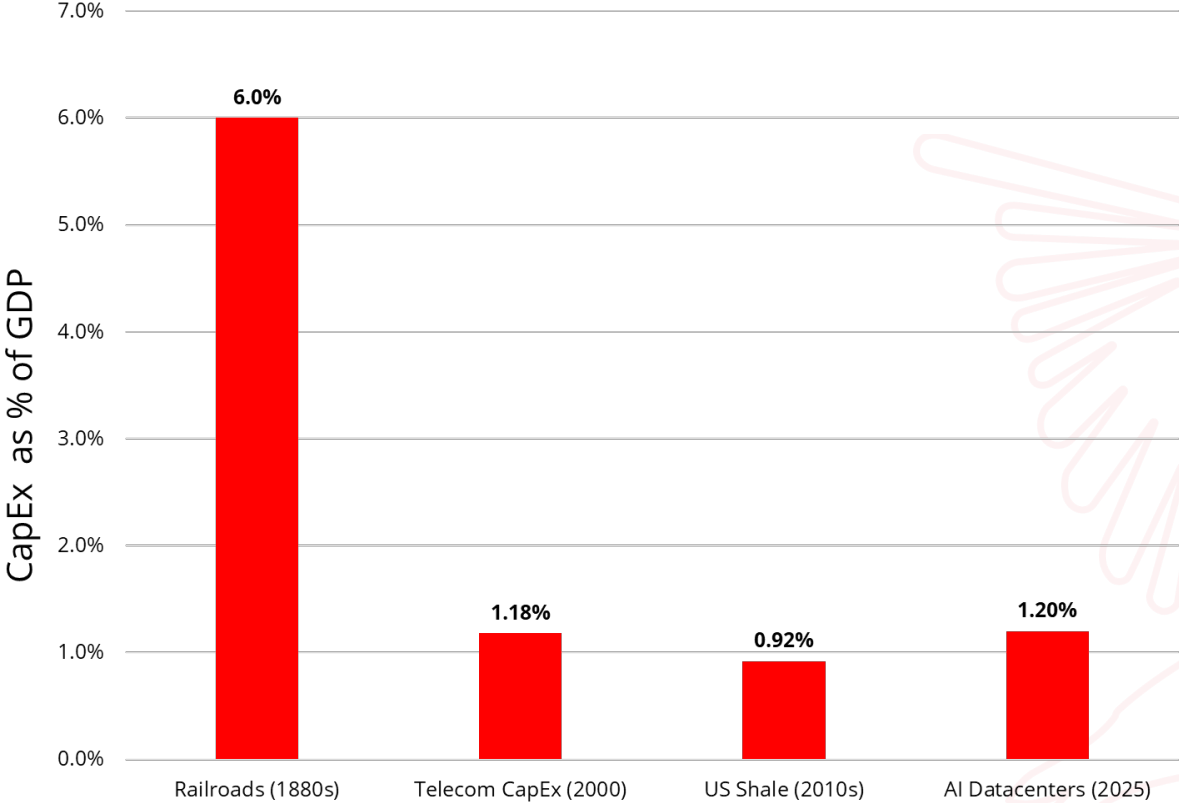

20
26

Past performance is no guarantee of future results. Source: paulkedrosky.com, Jens Nordvig, Federal Reserve Bank of San Francisco



Investment Excitement Ratio

$$\frac{\text{Buffett Indicator} \times \text{Market Concentration}}{\text{CapEx-to-GDP}}$$

	1880s	2000s	2010s	2025
Buffett Indicator	50%	137%	96%	225%
Market Concentration	80%	29%	12%	26%
CapEx-to-GDP	6.0%	1.2%	0.9%	1.2%
Excitement Ratio	7x	34x	13x	48x

Past performance is no guarantee of future results. Source: Bloomberg. Data as of 9/30/2025.

20
26



Investment Excitement Ratio

$$\frac{\text{Buffett Indicator} \times \text{Market Concentration}}{\text{CapEx-to-GDP}}$$

	1880s	2000s	2010s	2025
Buffett Indicator	50%	137%	96%	225%
Market Concentration	80%	29%	12%	26%
CapEx-to-GDP	6.0%	1.2%	0.9%	1.2%
Excitement Ratio	7x	34x	13x	48x

20
26

Past performance is no guarantee of future results. Source: Bloomberg. Data as of 9/30/2025.

Agenda

- ✓ **Railway Mania of the 1880s**
- ✓ **The Telecom Bubble**
- ✓ **Drill Baby Drill of the 2010s**
- ✓ **Today's AI Hyper-Scaling Mania**
- ✓ **Investment Excitement Ratio**
- **The Returns that Follow**





The Returns that Follow

IN THE 19TH CENTURY, RAILROADS WERE THE MARKET

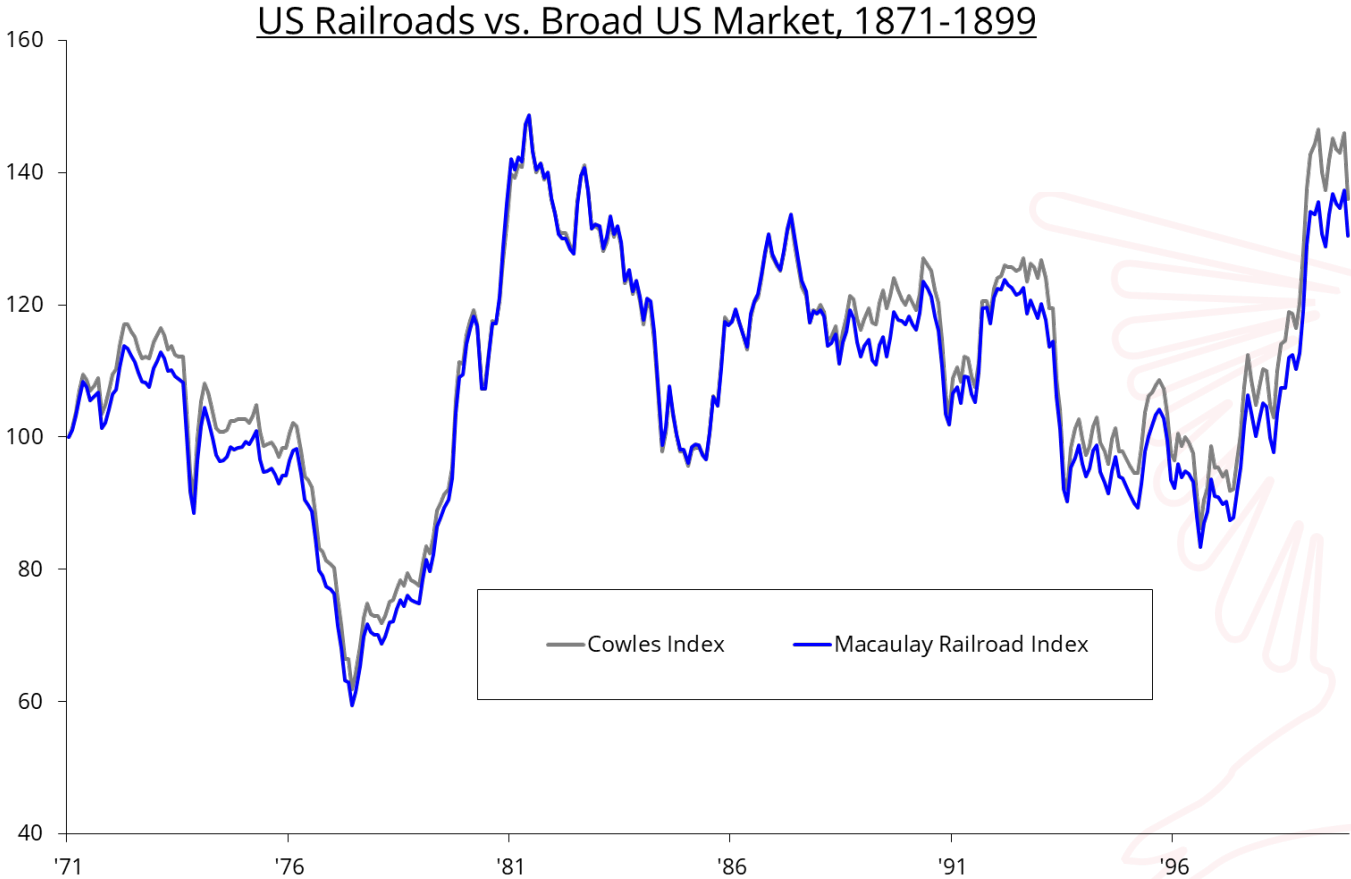

20
26

Past performance is no guarantee of future results. Source: Birinyi Associates



The Returns that Follow

IN THE 19TH CENTURY, RAILROADS WERE THE MARKET

US Railroads vs. Broad Market, 1900-1999

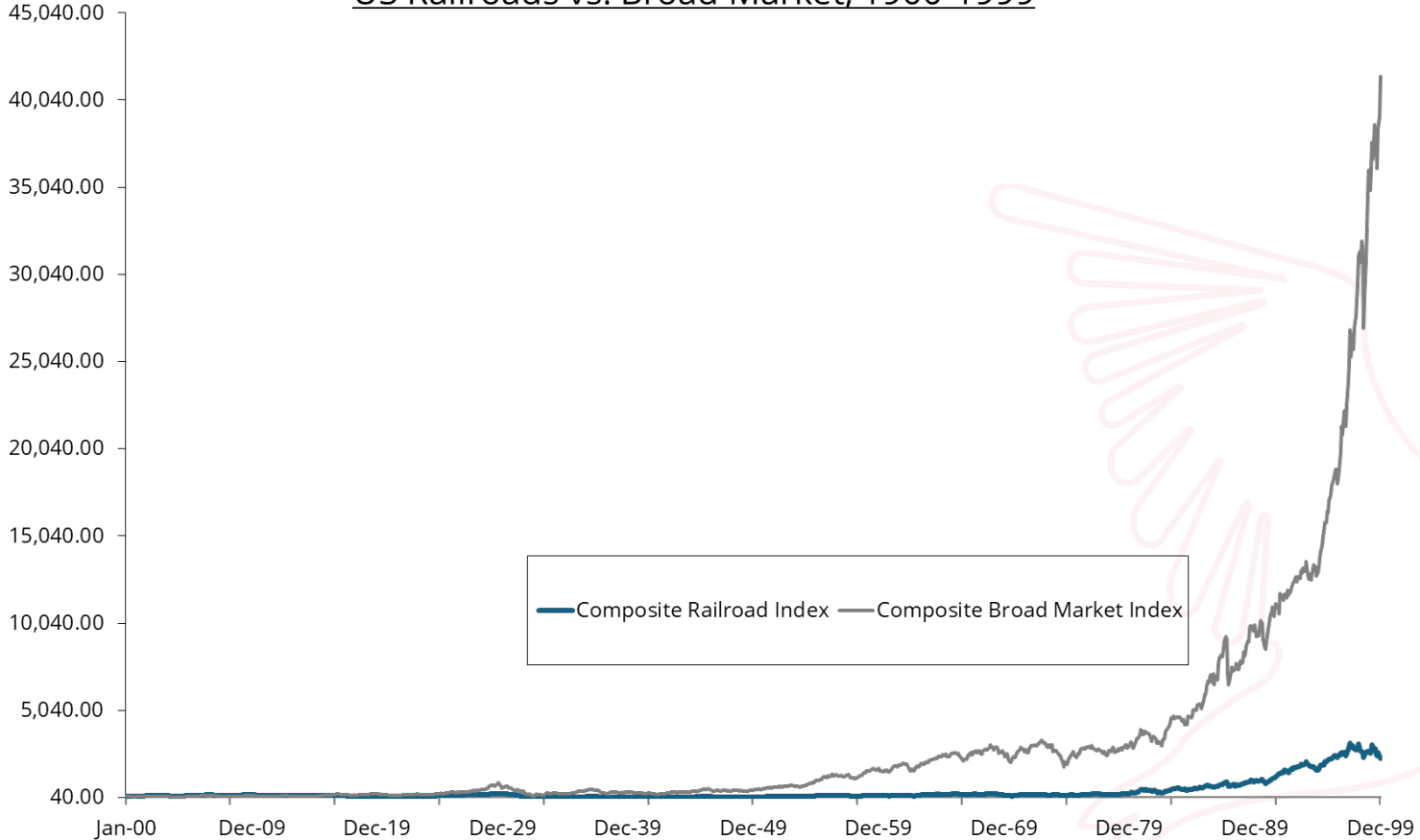

20
26

Past performance is no guarantee of future results. Source: Birinyi Associates



The Returns that Follow

TELECOM BUBBLE AFTERMATH

Telecom Total Returns, 2000-Present

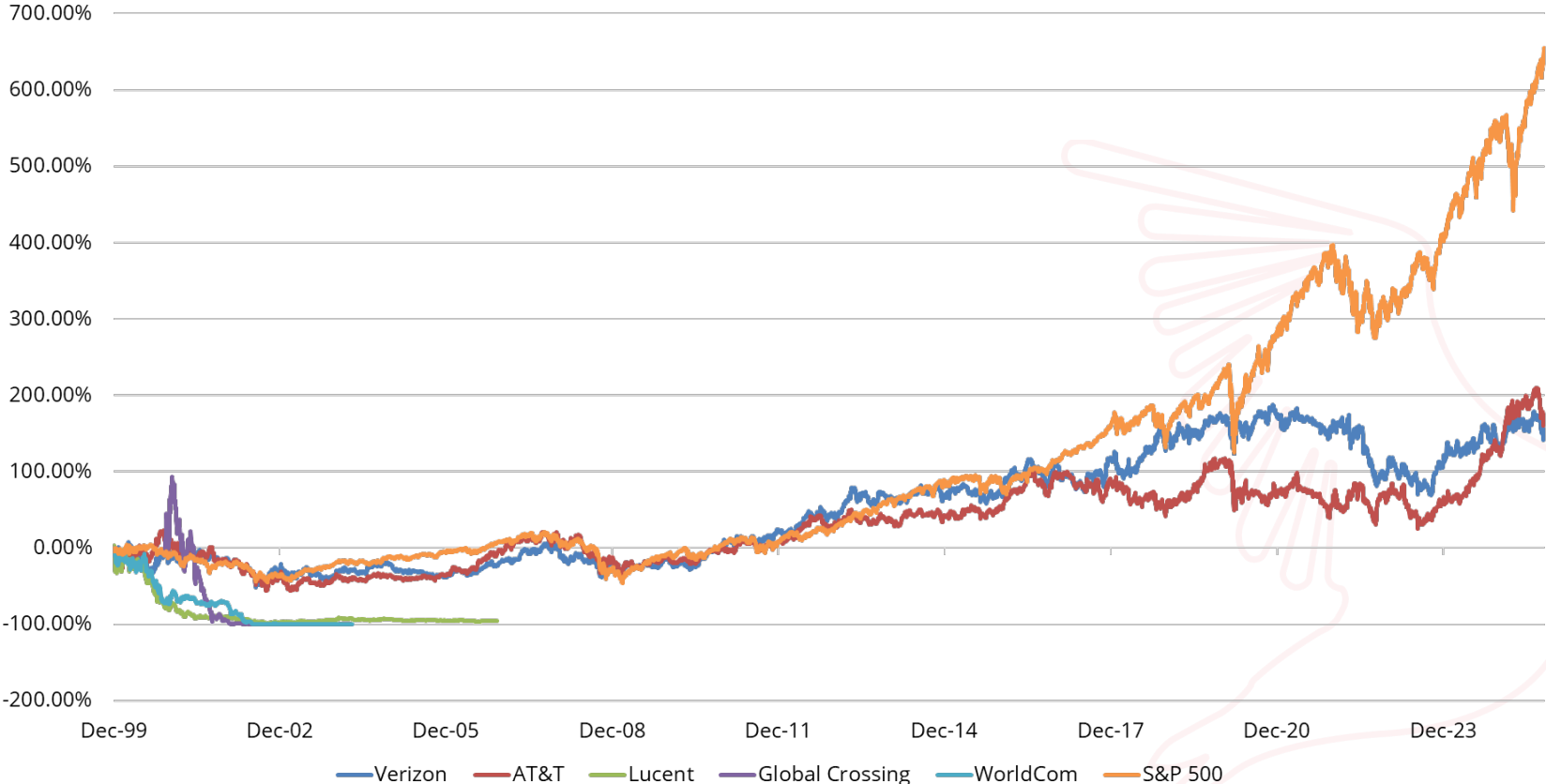

Past performance is no guarantee of future results. Source: Bloomberg.

20
26



The Returns that Follow

SHALE BUBBLE AFTERMATH

Oil Supermajor Returns vs. S&P 500, 2013-Present



Past performance is no guarantee of future results. Source: Bloomberg.

20
26



IMPORTANT INFORMATION

Information provided does not constitute investment advice and no investment decisions should be made based on any information provided. Information reflects the views of Smead Capital Management as of a particular time. Such views are subject to change without notice. Information regarding holdings, allocations and other allocations are for illustrative purposes only and may not be representative of current or future investments or allocations. This information is not a recommendation to purchase or sell a security or follow any strategy or allocation. Any forward-looking statements or forecasts are based on assumptions and actual results may vary from any statements or forecasts. While Smead Capital Management has used reasonable efforts to obtain information from reliable sources, no representations or warranties are made as to the accuracy, reliability or completeness of third-party information presented in this material. This material is not to be duplicated or recreated without prior written consent of Smead Capital Management.

Definitions:

Forward Price/Earnings (P/E): the ratio of a firm's closing stock price & its forward 12 months' earnings/share.



Questions & Answers

Information provided does not constitute investment advice and no investment decisions should be made based on any information provided. Information reflects the views of Smead Capital Management as of a particular time. Such views are subject to change without notice. Information regarding holdings, allocations and other allocations are for illustrative purposes only and may not be representative of current or future investments or allocations. This information is not a recommendation to purchase or sell a security or follow any strategy or allocation. Any forward-looking statements or forecasts are based on assumptions and actual results may vary from any statements or forecasts. While Smead Capital Management has used reasonable efforts to obtain information from reliable sources, no representations or warranties are made as to the accuracy, reliability or completeness of third-party information presented in this material. This material is not to be duplicated or recreated without prior written consent of Smead Capital Management.

Definitions:

Forward Price/Earnings (P/E): the ratio of a firm's closing stock price & its forward 12 months' earnings/share.

2502 East Camelback Road
Suite 210
Phoenix, AZ 85016

smeadcap.com
info@smeadcap.com

877.807.4122 Individual Investors
877.701.2883 Advisors, Family Offices
and Institutional Investors

